

THE CONAR MODEL 255 OSCILLOSCOPE



OSCILLOSCOPE SPECIFICATIONS

VERTICAL CHANNEL

Sensitivity

2 mV maximum, uncalibrated 10-20-50-100-200-500
mV/cm and 1-2-5-10-20 volts/cm calibrated

Input impedance

1 megohm paralleled by 30 pf

Frequency response

dc to 6 MHz ± 3 db

Rise time

60 ns

Input impedance

500k-ohm minimum

TRIGGERED SWEEP

Trigger source

Internal, external, and line

Calibrated ranges

1-2-5-10-20-50-100-200-500 μ S/cm and 1-2-5-10-20-50
ms/cm

HORIZONTAL CHANNEL

Sensitivity

50 mV

Input impedance

500k-ohm minimum

Frequency response

3 Hz to 1 MHz ± 3 db

Z-AXIS INPUT

Sensitivity

20 vpp

Impedance

Approximately 100k-ohm

EXTERNAL TRIGGER INPUT

Sensitivity

10 mV

SAWTOOTH OUTPUT

Output impedance

Approximately 18k-ohm

Waveshape

Linear, positive going sawtooth, 200 vpp

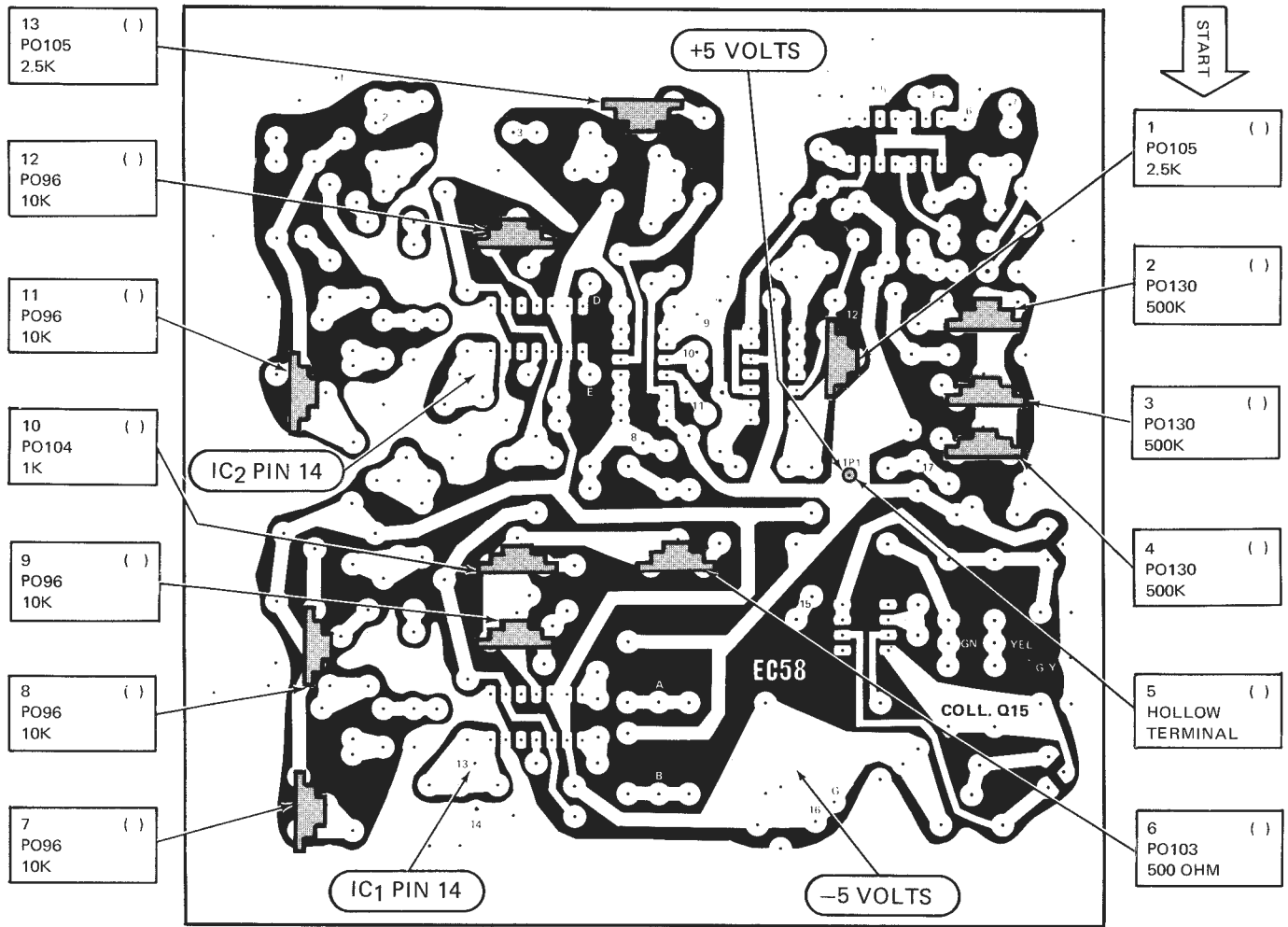

Fig. 6. Installing components on the foil side of EC58.

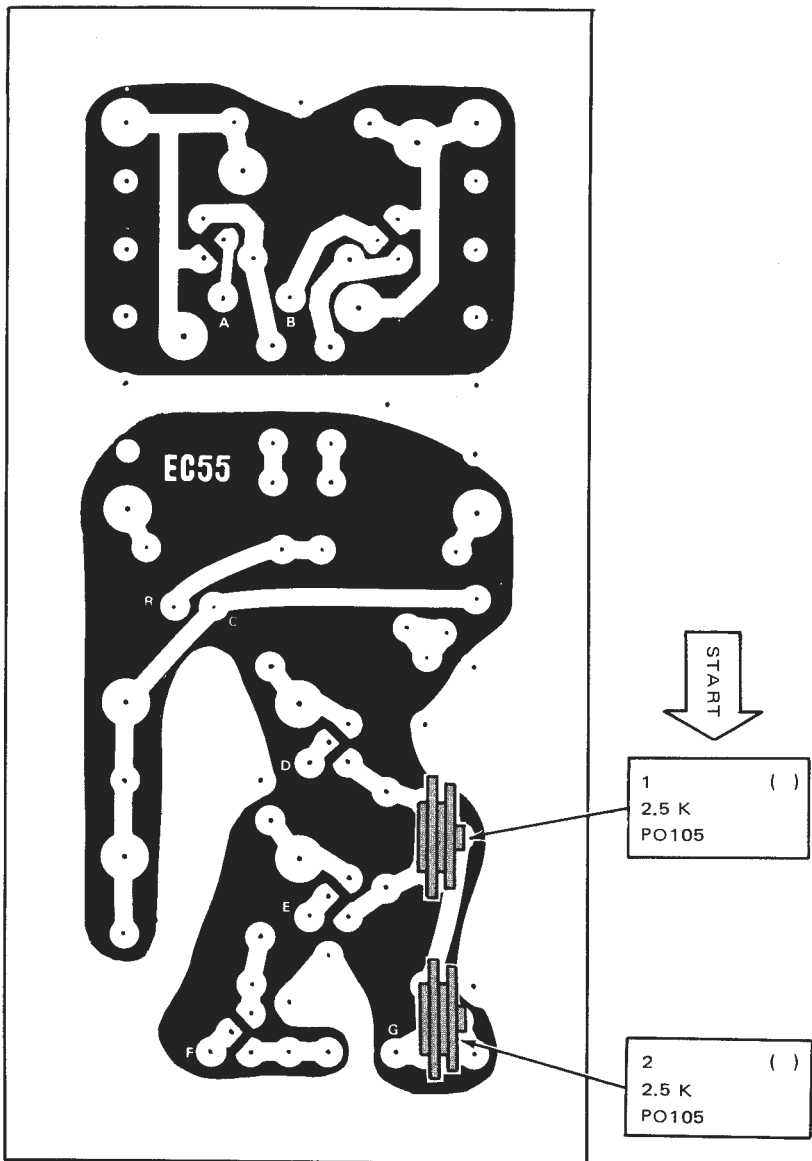
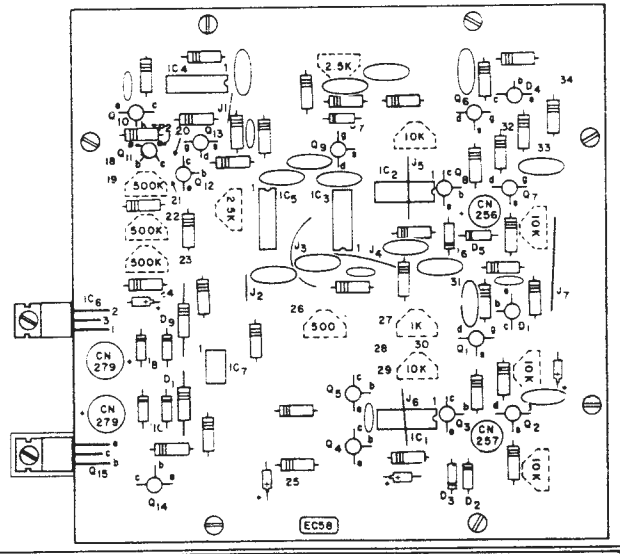
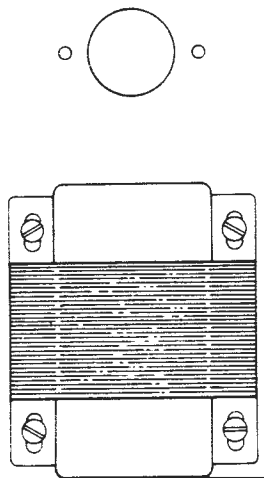
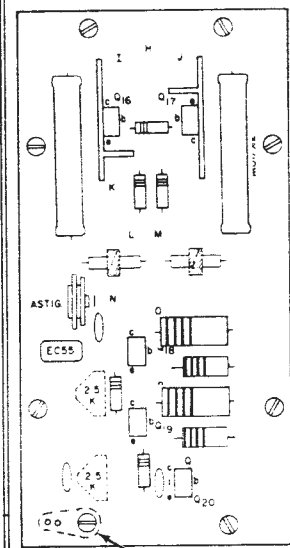

Fig. 9. Installing parts on the foil side of EC55.



NO. 6 SOLDER LUG
ON OTHER SIDE

Fig. 14. Mounting major parts on the components side of the chassis.

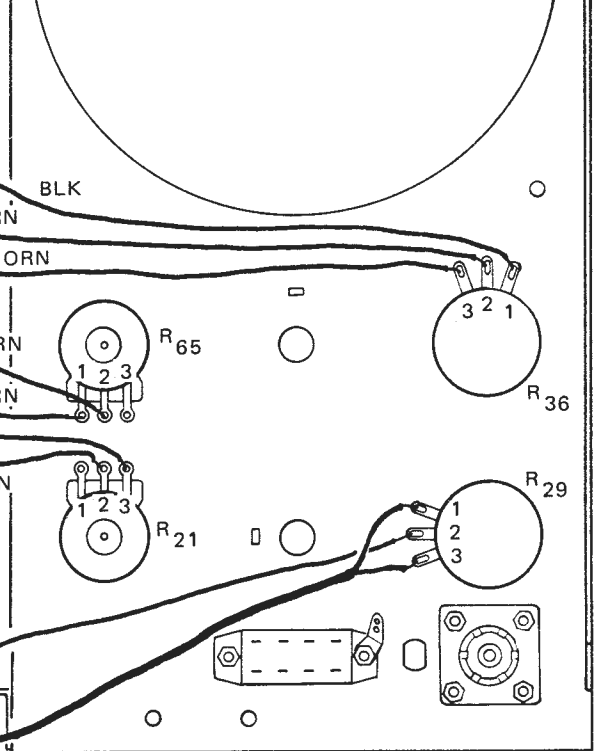
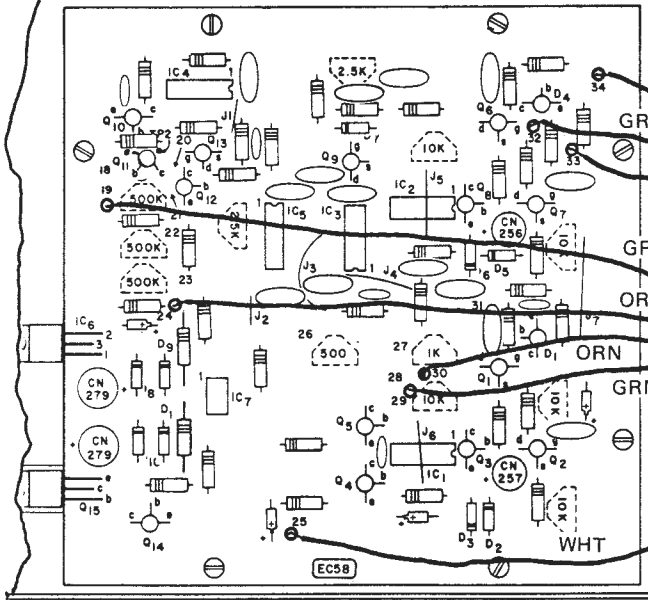
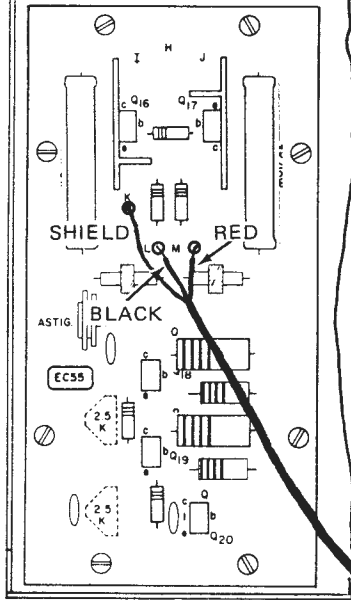

Fig.3. Installing diodes, IC sockets, tubular capacitors, and jumper wires on EC58.

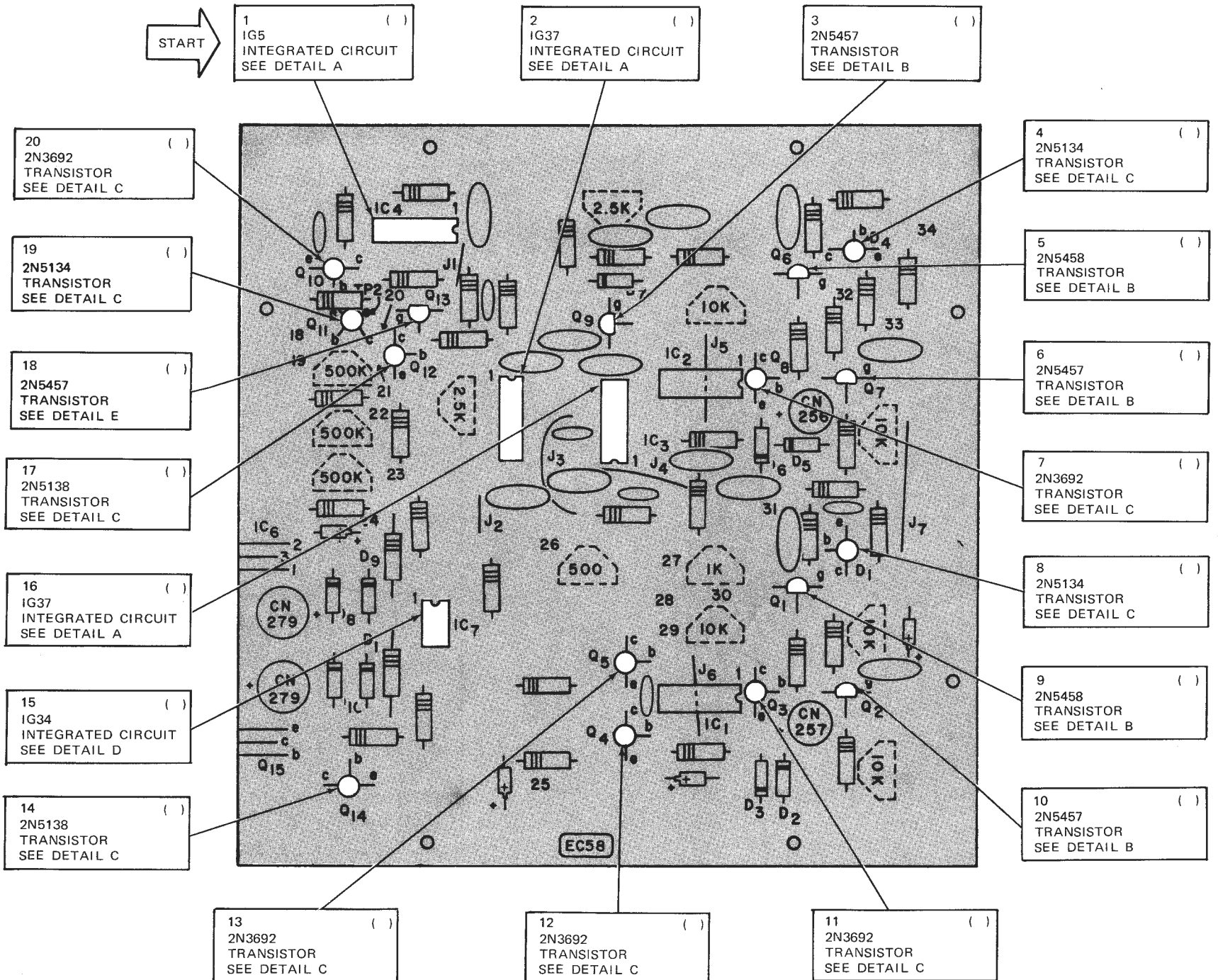

Fig.5. Installing the IC's and transistors on EC58.

CALIBRATION

If you do not get the results called for in the calibration instructions in this section, be sure to read over the Theory of Operation section beginning on page 39 and the Maintenance section beginning on page 56 before writing us for assistance. A few minutes spent with a voltmeter and the information contained in these two sections could possibly save you a great deal of time in tracking down a poorly soldered connection!

INITIAL TESTS

First, measure the voltage at Pin 14 of IC₁ (see Fig. 6, page 8) with a voltmeter set to its lowest range. As you monitor this voltage, carefully adjust the coarse and fine vertical balance controls (see Fig. 37) until this voltage is exactly zero. Now monitor the voltage at Pin 14 of IC₂ as you adjust the horizontal balance control (Fig. 37) for zero volt at this point. This adjustment should be made with the horizontal positioning control on the front panel set to the center of its adjustment. After you have made both of these adjustments, unplug the oscilloscope from the ac outlet and install the two IG36 (733) integrated circuits in the two empty IC sockets (IC₁ and IC₂) on the front circuit board. Note that Pin 1 (the notched end) of each IC must be towards the front of the oscilloscope. Make sure that all the IC pins are plugged into the socket and that the integrated circuit is fully seated in the socket.

Preset the front panel controls in accordance with Table 1 and the internal controls using Table 2. The rotation of all controls is as viewed from the knob end of the control. Turn the scope on and turn the intensity control clockwise until you see a line on the crt screen. Adjust the focus control until the line is as sharp as possible. Now turn up the intensity control to just below the point where the line begins to lengthen and go out of focus. This is the point of maximum usable intensity. The control should never be turned any higher than this. The oscilloscope calibration is valid only while the intensity is set at this point or lower. Again, adjust the focus control for maximum sharpness.

TABLE 1

EXTERNAL PRESETS

Vert. Input Sel.	GND
VOLTS/CM	5
Variable Gain	CCW
Vert. Pos.	Center
TIME/CM	500 μ S
Var. Time/Div.	CW
Horiz. Pos.	Center
Ext. Gain	CCW
Sweep Source	Line
Trigger Source	Line
Slope Sel.	+
Trig. Level	Center (0)

Turn the vertical position control back and forth and as you do this, the line should move up and down. The line should move up when you turn the control clockwise and down when you turn the control counterclockwise. Set the control so that the line appears at the center of the screen.

The line you see on the crt screen may not be perfectly horizontal. In this step you are to adjust the position of the crt so that the line is perfectly horizontal and so that it lines up with the markings on the graticule.

CAUTION

The voltages on the crt socket and rear circuit board are dangerous. Do not put your fingers near the crt socket or the heat sinks on the rear circuit board. All crt position adjustments must be made with the power removed and only after all filter capacitors have been given enough time to discharge to a safe level.

Note the angle of the line on the crt in relation to the horizontal lines on the graticule. Unplug the oscilloscope from the ac outlet and allow one full minute for all filter capacitors to discharge. Now loosen the crt clamp and turn the crt from the rear to the position that you estimate will be the correct one. Also, push the crt forward so the graticule is pressed tightly to the inside of the bezel. Plug in the power cord again and after the crt warms up, note the position of the line. If it is now perfectly horizontal, fine. If not, repeat the adjustment procedure until it is exactly right. *Do not fool yourself into believing you can make the position adjustment with power applied if you are careful enough.* Unplug the line cord each time and wait one full minute for all filter capacitors to discharge. Be patient. Remember, you will never need to make this adjustment again, unless you should happen to replace the

TABLE 2

INTERNAL PRESETS

Astig.	Center
Horiz. Output Bias	CCW
Horiz. Output Bal.	Center
Horiz. Bal.	*
Vert. Bal. Coarse	*
Vert. Bal. Fine	*
Vert. Gain 1	CCW
Vert. Gain 2	CCW
Vert. Gain 5	CCW
Trig. Bal.	Center
Sweep Bal.	CW
Sweep Cal. 1	CW
Sweep Cal. 2	CW
Sweep Cal. 5	CW
Horiz. Gain	CCW

*Already set—do not touch.

crt. When you finish, make sure that the crt is still pushed up against the graticule to hold it in place.

Turn the horizontal position control back and forth and note that the line moves horizontally. The line should move to the right when you turn the control clockwise and to the left when you turn the control counterclockwise. Move the Sweep Source switch to the external (EXT) position. You should now see only a single dot on the screen. Adjust the horizontal output balance potentiometer on the rear circuit board to center the dot horizontally on the screen. Now put the Sweep Source switch in the LINE position.

The vertical input connector on the front panel is designed to accommodate a screw-on coaxial connector, standard banana plug, or dual banana plug. Insert the banana plug of the red test lead into the vertical input jack (not the black ground jack) and clip the other end of the test lead to the end of the green transformer lead which is protruding from the components side of the front circuit board between D₉ and D₁₁. There is an ac voltage at this point that you will use as test signal for the following steps. We will call this point the *low-voltage ac test point*.

At this point, you should see a single horizontal line on the crt screen. Now, move the input switch to its direct current (DC) position. You should now see an ellipse on the screen. Remember, you have not yet calibrated your oscilloscope, so you won't be able to measure the amplitude or frequency of the signal at this time.

Move the input switch to the AC position. There is no dc offset in the signal that you are observing, so the waveform should be the same as in the previous paragraph. Move the input switch back to the dc position.

Rotate the VOLTS/CM switch counterclockwise, and the vertical dimension of the waveform on the crt should become smaller. Turn the switch clockwise and the waveform should become larger. Return the switch to the "5" position.

Turn the Variable Gain control clockwise. The waveform should become larger. Turn the control fully counterclockwise to its original position.

Remove the clip lead from the low-voltage ac test point and very carefully clip it to the center terminal of the Slope switch. This is the terminal with the single-conductor cable attached. Make sure the Trigger Level knob on the front panel is centered with the dot straight up at "0," then slowly adjust the TRIG BAL control (see Fig. 37) while you watch the screen. As you adjust this control you should see the horizontal line on the screen split into two parts, one above the other connected by a short vertical space. The space should move left and right as you rotate the TRIG BAL control back and forth, causing the two horizontal line segments to increase and decrease in length.

Adjust the TRIG BAL control so that the vertical space is in the exact center of the line and the two horizontal lines are the same length. Rotating the Trigger Level control should now move the vertical space left and right as the TRIG BAL did before. Place the Slope switch in the "minus" (-) position and check to see that the Trigger Level control moves the vertical space left and right once again. Place the input switch in the GND position and move the clip lead back to the low-voltage ac test point.

You will next adjust the sweep balance (SWEEP BAL) and

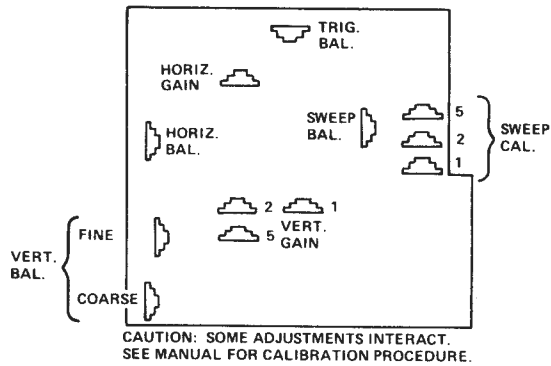

Fig. 37. Internal control identification.

horizontal gain (HORIZ GAIN) potentiometers which are also located on the front circuit board as shown in Fig.37. First switch the Sweep Source to EXT and make sure the dot is centered on the crt screen. Use the horizontal and vertical position controls to accomplish this. Now set the Sweep Source switch to INT and the Trigger Source switch to LINE. Next adjust the sweep balance (SWEEP BAL) potentiometer counterclockwise. You should see the left end of the line move to the left on the crt screen. Continue turning the potentiometer until the left end of the line almost coincides with the first vertical line of the graticule. Now turn the horizontal gain control until the left end of the line touches the first vertical line of the graticule, and the right end of the line touches the last vertical line of the graticule. Alternately adjust the SWEEP BAL and HORIZ GAIN Controls so that the horizontal line extends from the leftmost to the rightmost vertical lines of the graticule. When you have reached this condition, the SWEEP BAL and HORIZ GAIN are correctly adjusted.

Now switch the vertical input selector switch to DC and the familiar sine waveshape should appear on the screen. The signal may appear somewhat distorted because the low voltage rectifiers cause uneven loading on the power transformer windings from which this signal is taken. The vertical line which is at the left end of the trace is a normal result of the type of retrace blanking used in your oscilloscope. The line should coincide with the leftmost vertical line of the graticule and will show you graphically the exact starting point of the waveform being displayed.

The focus control is used to sharpen the crt image near the center of the screen. Now that you have a fairly large trace on the screen, you may notice that on the extremes on the screen the focus is poor. Compensate for this by adjusting the Astigmatism control, which is located on the rear circuit board. Access is provided to this control through a small hole in the rear panel. Adjust the control with a small screwdriver. There will be some interaction between the focus and intensity controls. The idea is to make the trace as sharp as possible in all areas of the screen. Once the Astigmatism control is set, it should not need readjustment.

Now that you have established the gain of the horizontal amplifier, you can proceed with the sweep calibration. Set the TIME/CM switch to its 5 milliseconds (5 mS) position and the Variable Sweep control fully clockwise. Now adjust the top sweep calibrate potentiometer (5 in Fig. 37) until you see three complete cycles of the input waveform from the extreme left

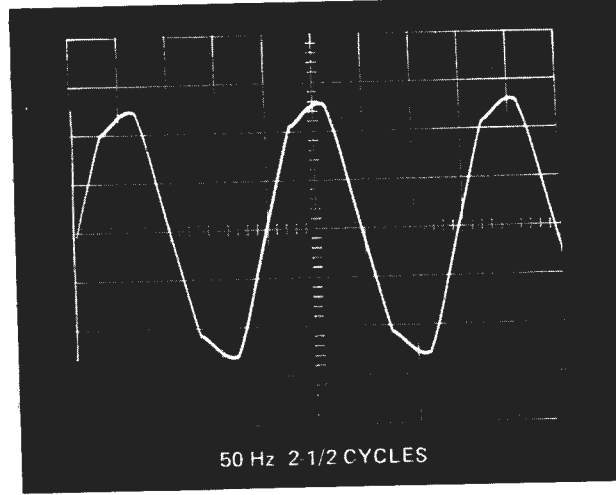
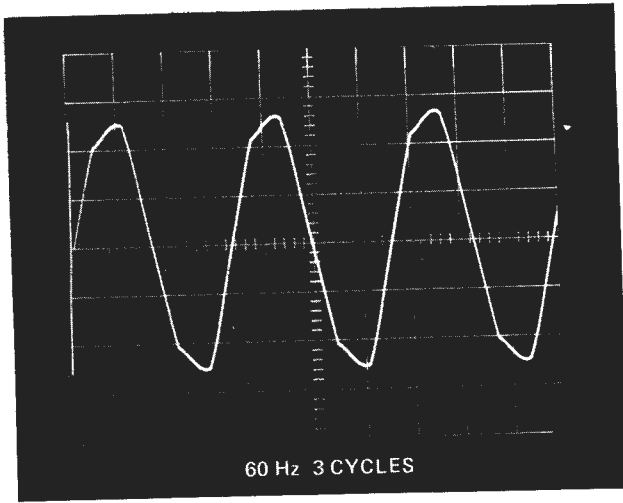

Fig. 38. Waveform for adjusting Sweep Cal. 5.

marking on the graticule to the extreme right marking. (If your scope is connected to a 50 Hz power line, you should adjust for two and a half complete cycles.) See Fig. 38. Turn the TIME/CM switch one position clockwise to the 2 milliseconds position. Refer to Fig. 39 and adjust the center sweep calibration potentiometer (2) so that one cycle of the

waveform takes up exactly 8-1/3 centimeters on the face of the screen. (If your scope is connected to a 50 Hz power line, you should adjust the control so that one cycle fits the width of the graticule—10 cm.)

Now turn the TIME/CM switch two positions clockwise to the 10 milliseconds position. Refer to Fig. 4

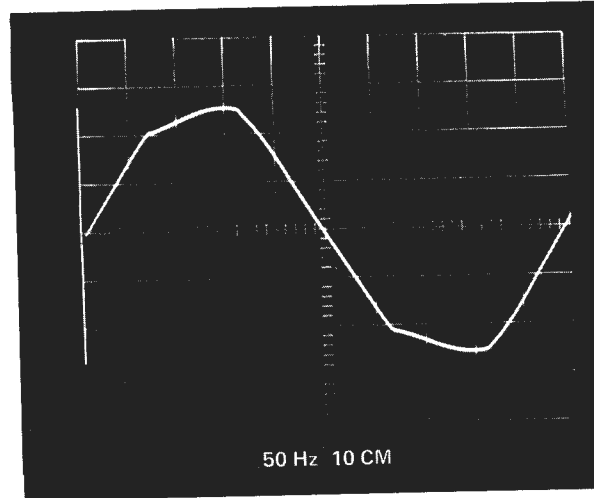
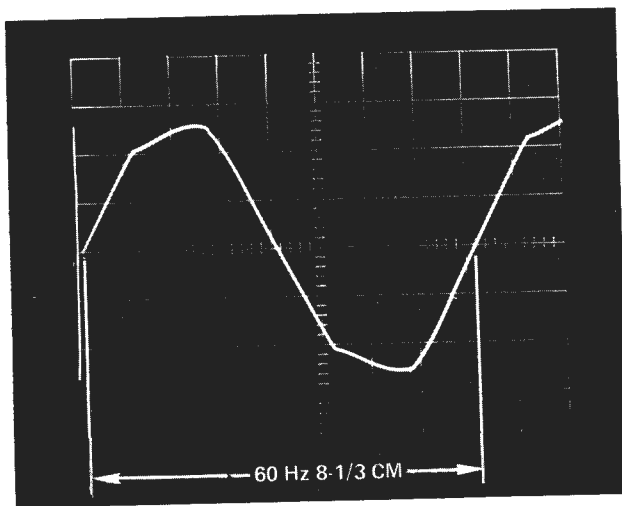

Fig. 39. Waveform for adjusting Sweep Cal. 2.

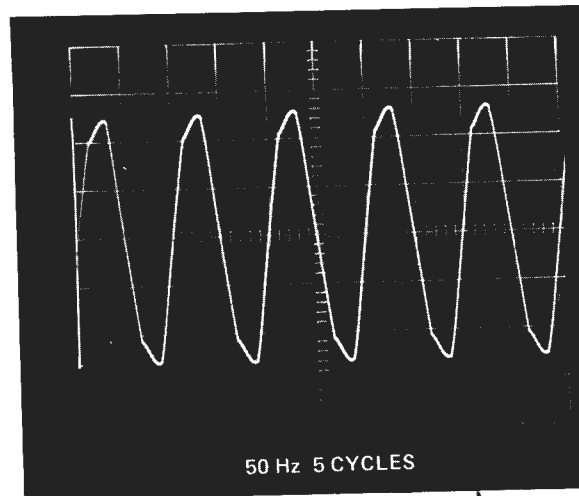
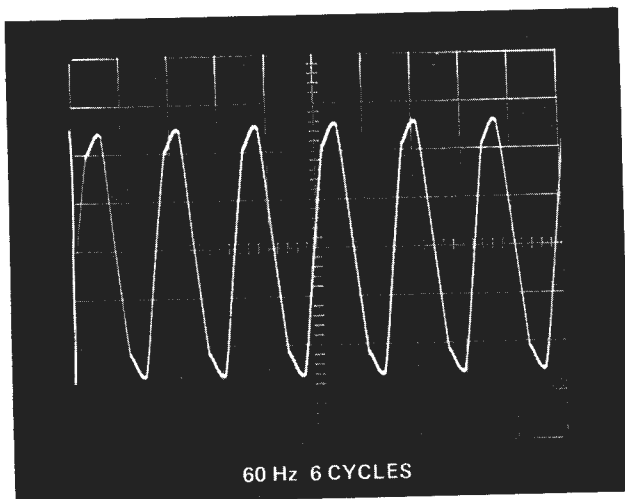

Fig. 40. Waveform for adjusting Sweep Cal. 1.

Adjust the bottom sweep calibrate potentiometer (1) so that you see exactly six full cycles of the input waveform across the 10 centimeter width of the screen (five full cycles if your scope is connected to a 50 Hz power line).

This completes the sweep calibration of your oscilloscope. It's now go ahead with the amplitude calibration of the vertical amplifier. The voltage reference for the amplitude

calibration will be the +5 volts output of the three-terminal voltage regulator (IC₆) in the power supply. This voltage is guaranteed by the IC manufacturer to be within $\pm 4\%$ of the 5-volt nominal output.

Move the Sweep Source selector switch to the LINE position, and move the vertical input clip lead from the low-voltage ac test point to TP₁ on the foil side of the front circuit board (EC54).

Refer to Fig. 41 for the following steps. Set the vertical input switch to the GND position and the VOLTS/CM switch to the "5" position. Adjust the vertical position control so that the line coincides with the center horizontal line on the graticule. Now move the input switch to DC and you will notice that the line moves up. Adjust the vertical gain calibrate potentiometer, labeled 5 in Fig. 37, so that the line moves up exactly one centimeter (to the next line on the graticule). There will be some interaction between the gain adjust potentiometer and the vertical position control, so switch back and forth between GND and DC several times, each time readjusting the position and gain calibrate controls so that the line moves exactly one centimeter each time the switch is thrown.

Now switch the VOLTS/CM switch to the "2" position and adjust the vertical gain calibrate potentiometer, labeled 2, for a movement of exactly 2-1/2 divisions each time you move the input switch from GND to DC. Again, there may be some interaction between the calibrate and position controls. Switch back and forth several times to make sure that the vertical movement is exactly 2-1/2 divisions.

Now set the VOLTS/CM switch to the "1" position and turn the vertical position control counterclockwise so that the trace coincides with the horizontal line immediately *below* the one at the center. When you throw the input switch to DC, the trace should move up exactly 5 divisions, to the very top of the screen. Adjust the vertical gain calibrate potentiometer, labeled 1, so that exactly a 5-division shift is noted each time you throw the switch. Once again, there will be some interaction between the position and the gain adjust controls, so switch back and forth several times to be sure the calibrate control is set accurately.

You will now make an adjustment that compensates for offset voltage in the input of the vertical amplifier. This adjustment should be set so that there is *minimum movement* of the trace when the position of the Variable Gain control is changed but no input signal is applied. Set the input switch to GND and turn the Variable Gain control fully clockwise and back a few times. You will probably see some shift as you rotate the control. Carefully adjust the fine vertical balance potentiometer until this shift is no longer noticeable. It may not be possible to eliminate the shift altogether but you should be able to reach a point where it is almost unnoticeable. Note that the control that you are adjusting may be somewhat sensitive to hum pickup, so adjust the control slightly, then move your hand away to judge the results of the adjustment.

If you are unable to find a setting of the fine vertical balance potentiometer that results in very little movement of the trace as you move the Variable Gain control, try the adjustment again using a slightly different setting of the coarse vertical balance potentiometer. Repeat the procedure as many

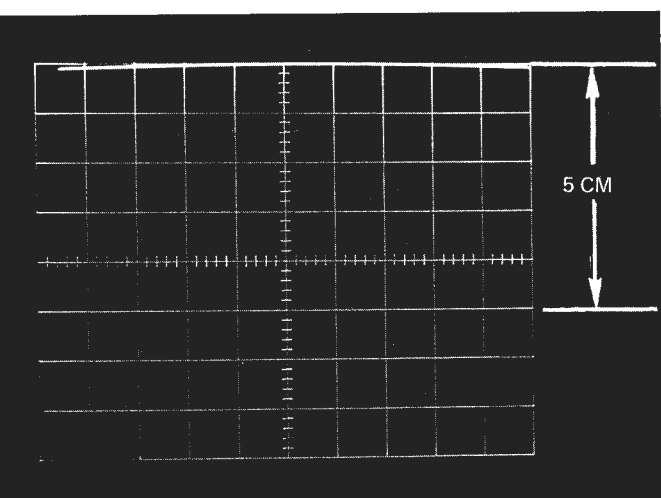
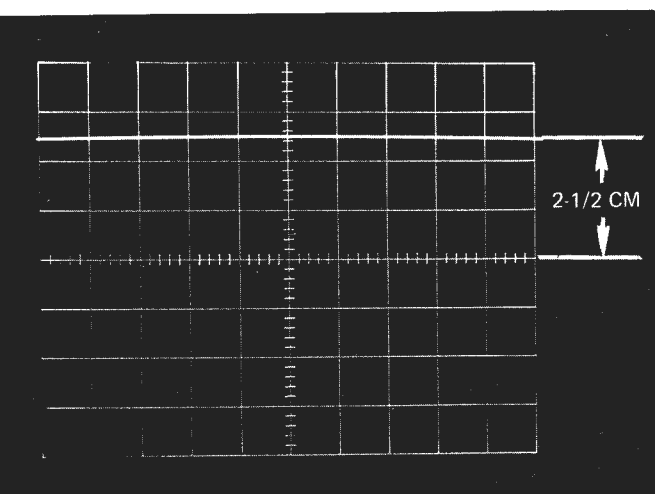
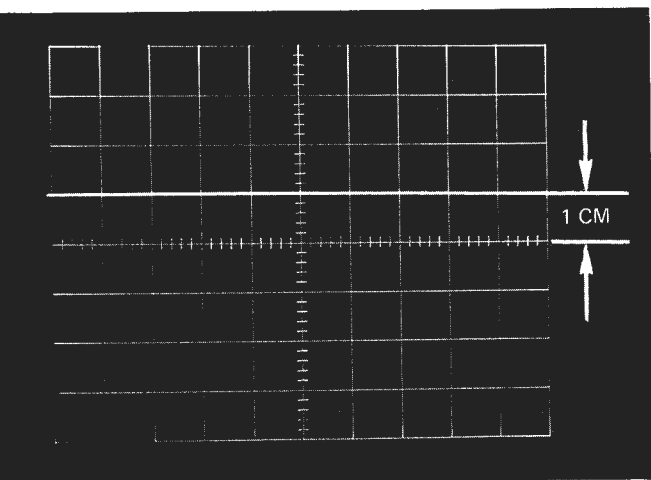
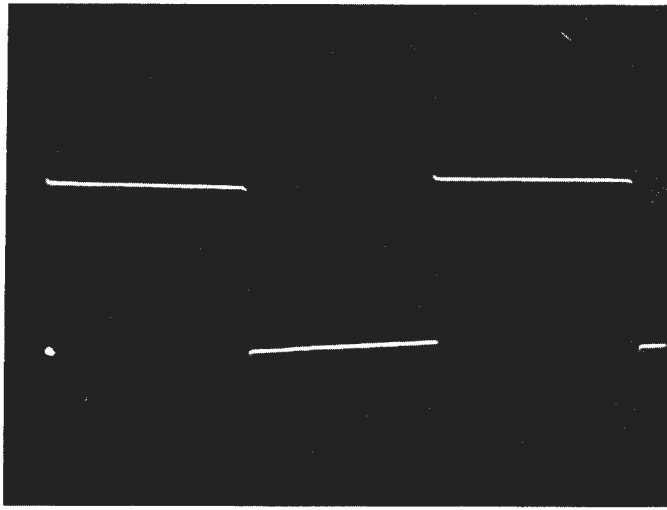
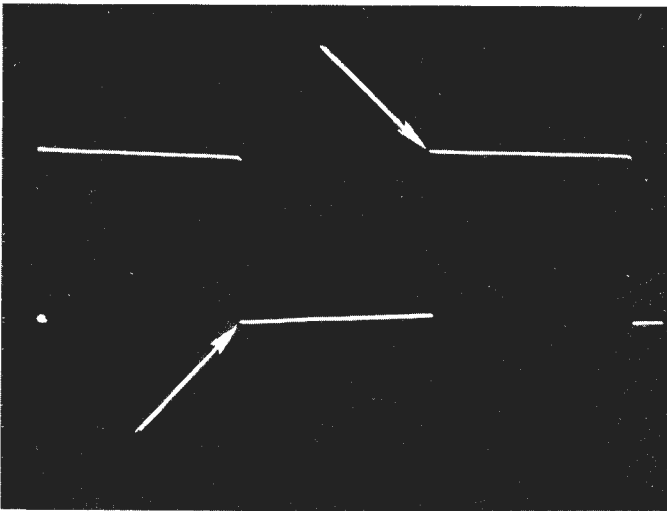

Fig. 41. Waveform for vertical gain calibration.



(A)



(B)

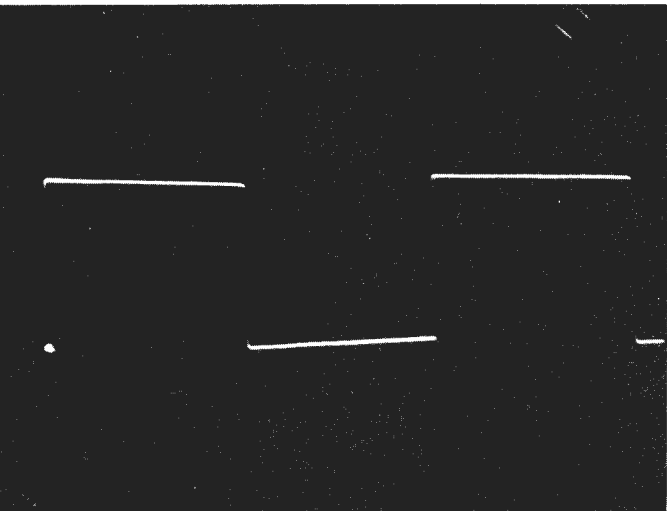

(C)

Fig. 42. Waveforms with the VOLTS/CM switch set to 1 showing overcompensated (A), correctly compensated (B), and undercompensated (C) adjustment of the vertical attenuator trimmer.

times as necessary, using a different position of the coarse potentiometer each time, until you achieve the proper combination of settings.

The final set of adjustments which you must make are the frequency compensation adjustments for the vertical attenuator. There are three of these adjustments, all located on the attenuator switch. Each of the three trimmer capacitors mounted on the switch is associated with one of the input attenuators. Only one of these attenuators is used at any one setting of the VOLTS/CM switch, and you should notice no interaction among the three trimmer adjustments.

Move the vertical input clip lead from TP₁ to the center terminal of the Slope switch. Set the TIME/CM switch to 2 mS, the Trigger Source switch to LINE, the Sweep Source switch to INT, the VOLTS/CM switch to 1, and the input switch to AC. Adjust the Trigger Level control to display a pattern similar to that shown in Fig. 42.

We have removed the graticule in Fig. 42 to make the waveforms clearer. In making the compensation adjustments you will be looking at the two areas indicated in Fig. 42(B). The adjustments should be made to make these two corners as square as possible without overshoot [Fig. 42(A)] or rounding [Fig. 42(C)].

Refer to Fig. 43 for identification of the three trimmer capacitors mounted on the VOLTS/CM switch. It is best to use a nonmetallic screwdriver to adjust the trimmers. If you do not have such a tool, at least use a screwdriver with a long blade and an insulated handle. Keep your hand well back on the insulated part to minimize any hand-capacitance effects.

Since you have the VOLTS/CM switch set to 1, you will first adjust C₄ for a waveform like Fig. 42(B). When you have completed this adjustment, switch the VOLTS/CM switch to 0.5. The tops and bottoms of the waveform may appear tilted; however, disregard this and adjust C₂ for the squarest corners. You may have to adjust the Vertical Position to see the top and bottom of the waveform. Finally set the VOLTS/CM switch to 10 and adjust C₆.

This completes the tests, adjustments, and calibration of your oscilloscope. Remove the clip lead from the Slope switch and the vertical input jack. Putting the side panels on the cabinet will complete the assembly of your oscilloscope.

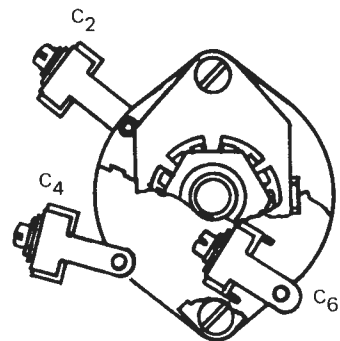

FRONT VIEW OF
VOLTS/CM SWITCH

Fig. 43. How to identify C₂, C₄, and C₆.

THEORY OF OPERATION

The circuitry of the Model 255 oscilloscope can be divided into four sections: the vertical amplifier, the horizontal amplifier, the sweep generator, and the power supply. Refer to the block diagram, Fig. 45, for the following general description of how these sections fit together to form the complete oscilloscope.

The vertical amplifier receives the signal to be observed by the oscilloscope, amplifies this signal by the setting of the VOLTS/CM switch on the front panel, and applies the signal, in push-pull form, to the vertical deflection plates of the cathode ray tube (crt). A sample of the vertical signal is also made available to the sweep section for triggering. The vertical amplifier includes controls for ac or dc coupling, vernier

adjustment of gain, and vertical positioning of the trace on the crt screen. This section of the oscilloscope features high gain and wide bandwidth.

The horizontal amplifier is very similar to the vertical amplifier, but the circuit is somewhat simplified because of the relaxed gain and bandwidth requirements. This section of the oscilloscope must take a sweep signal, which may be generated by the sweep circuit or by an external source, amplify this signal, and apply it, again in push-pull form, to the horizontal deflection plates of the crt. The horizontal amplifier includes controls for selection of its signal source and for horizontal placement of the trace on the crt screen. The Horizontal/Trigger (H/T) Gain control on the front panel affects the level

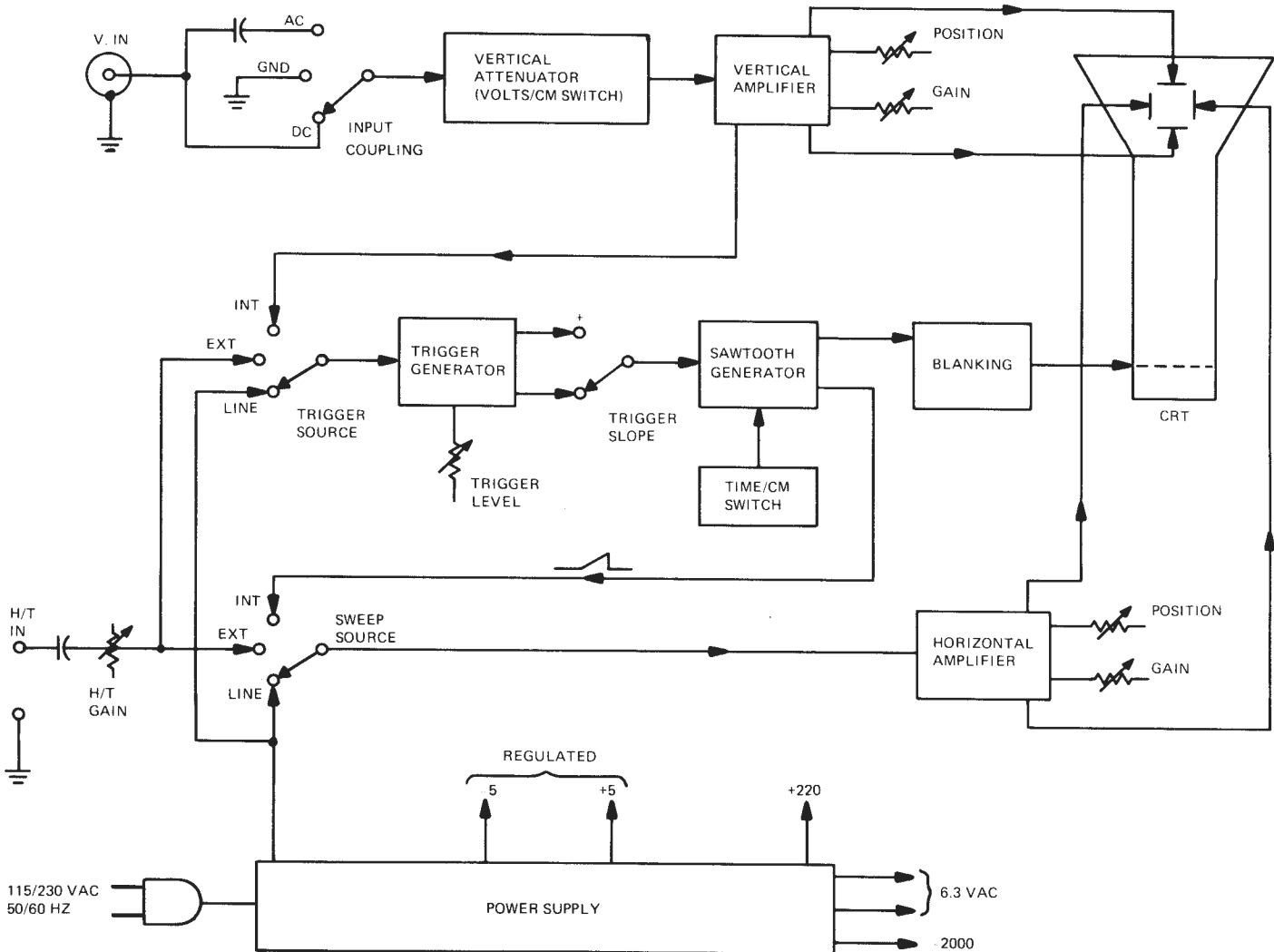

Fig. 45. Block diagram of Model 255 oscilloscope.

of only the *external* horizontal or trigger signal; it does not vary the width of the trace in the internal or line sweep modes.

The external sweep input is ac coupled, but the horizontal amplifier itself is direct-coupled to the output of the sweep circuit for best performance at very low sweep rates.

The sweep generator section can be considered as three subsections: the trigger generator, sawtooth generator, and blanking subsections. The function of the trigger generator is to convert the trigger input signal into a pulse suitable for application to the sawtooth generator circuit. The triggering level is adjusted with a front panel control. The front panel Trigger Slope switch selects whether the trigger occurs on the positive-going or the negative-going portion of the applied signal.

The purpose of the sawtooth generator is to generate a high-linearity sawtooth waveform for application to the horizontal amplifier. The sawtooth generator in the Model 255 is a triggered sweep; that is, it operates only when it is told to do so. The command to sweep comes from the trigger generator. Once a sweep is initiated, the sawtooth generator will ignore all further trigger pulses until the sweep and its retrace are completed. What this means to you, the user of the oscilloscope, is that the sweep is highly stable and is not affected by changes in input frequency. The use of a triggered sweep also allows horizontal expansion of the signal to a degree not possible with conventional recurrent sweep generators.

At the end of each sweep, during the time that the sweep output voltage is rapidly falling toward its originating point, the blanking amplifier applies a large negative-going pulse to the grid of the crt. This causes the beam to cut off and light output from the crt to cease. Since this happens while the electron beam is being swept back to the left side of the screen for the next sweep, the retrace line is effectively blanked.

The power supply section of the oscilloscope supplies all operating voltages to the other three sections. The high voltage supply develops -2000 volts for the crt electron gun, +220 volts for the vertical and horizontal output amplifiers and the blanking amplifier, 6.3 volts ac for the crt heater, and develops a regulated +5 and -5 volts for all other oscilloscope circuitry. In addition, one of the transformer windings also supplies a small ac voltage for use in the line sweep and line trigger modes.

Now that you are familiar with the overall operation of the various sections of the oscilloscope, refer to the complete schematic diagram on the separate insert sheet as we begin the detailed circuit description. You will start with the vertical amplifier.

THE VERTICAL AMPLIFIER

To get from the vertical input jack to the actual input of the vertical amplifier, the signal must pass through two switches: S_1 , the input switch, and part of S_2 , the VOLTS/CM switch. On the schematic diagram, S_1 is shown in its center position. Note that the vertical input jack is *not* shorted to ground. However, the *output* of the switch *is*. The purpose of this connection is to remove the input signal without the inconvenience of having to physically disconnect the probe from the input jack.

The main purpose of the input switch is to allow selection of ac or dc coupling of the input signal. This amounts to a switching between a direct connection from the input jack to the vertical amplifier to placing a capacitor between the two points.

The coupling capacitor, C_1 , is used only in the ac position of S_1 . This allows the oscilloscope user to observe a small ac signal which is superimposed on a large dc voltage – for example, a ripple waveform at the output of a dc power supply.

Once the signal passes through the input switch, it is applied to the attenuator switch S_2 . Actually, there is more to the VOLTS/CM switch than selecting the different attenuators, but you will get into that later on. For now, you will consider the attenuator switch portion only. As you can see from the schematic, S_2 can select three different compensated attenuators, or you can select a direct connection which provides no attenuation at all. The three attenuators provide voltage divisions of 10:1, 100:1, and 1000:1. Each of these voltage dividers uses a frequency compensated network to maintain flat frequency response across the bandwidth of the scope.

The vertical signal is coupled from the output of the attenuator of the selector switch to the gate of Q_1 through a network consisting of R_9 , C_9 , and D_1 . The purpose of this network is to protect the input circuitry of the scope from large input signals. Because of this input protection circuit, it is nearly impossible to cause damage to the oscilloscope by any combination of attenuator settings and input voltages. However, it is always wise to be cautious in such matters. Pretend that there is no such input protection circuit in your oscilloscope and operate the instrument accordingly. Use the highest attenuator setting first (20 VOLTS/CM) and reduce the attenuator as necessary to get a suitably sized display on the crt.

Field effect transistor Q_1 is used as a source follower to provide high input impedance. Q_2 serves as a constant-current source for Q_1 , and the output of the combination is direct-coupled to Q_3 , which is a bipolar emitter follower. The combination of the three transistors produces a voltage gain near unity. In other words, the signal level at the input of IC_1 is nearly the same as that at the output of the attenuator selector switch. Diodes D_2 and D_3 provide protection for the IC should one of the input transistors fail.

The no-signal dc voltage at the input of IC_1 must be as close to zero as possible to prevent trace shift as the gain of IC_1 is changed. The balancing potentiometers associated with Q_2 are set to achieve this condition. In addition to providing a current source for Q_1 , Q_2 serves to reduce thermal drift of the input stage by compensating for temperature effects in Q_1 . The two FET's are of the same type and are mounted in close proximity to each other, so changes in temperature will affect both equally. The circuit is configured so that the changes cancel out, and the result is an input stage whose output is affected only slightly by temperature variations.

The vertical-amplifier integrated circuit, IC_1 , is a differential video amplifier. It serves as a high-gain amplifier stage and as a phase inverter. Notice that there is only one input (Pin 14) to this IC, but there are two outputs (Pins 7 and 8). Another important contribution of the IC is that of providing gain

control. For example, you can see from the schematic that the same input attenuator is used in the "1," "2," and "5" positions of the input VOLTS/CM switch. Since the attenuation factor is not changing, you must change the gain of the vertical amplifier before you can change the sensitivity to correspond to the front panel markings. This is accomplished by changing the gain of IC₁ by connecting different values of resistance between Pins 4 and 11. Three different fixed resistance values are connected to the IC, depending upon the setting of the VOLTS/CM switch. Each time you turn the switch far enough to change to another attenuator, you begin the gain switching cycle over again.

Figure 46 on the separate insert sheet shows the (A) large jumps in sensitivity caused by different attenuators and the (B) small jumps, produced over and over, which are contributed by the gain switching resistors. The net results shown in (C) reveal the gain as being more or less smoothly varied from one extreme to the other. The exact resistor values connected by the gain switching terminals on the VOLTS/CM switch were set in the calibration procedure. R₂₁ provides front panel adjustment of the gain of the IC, so that the gain can be continuously varied for special measurements. Normally, however, this control is kept fully counterclockwise (maximum resistance), otherwise the gain calibration of the oscilloscope is not valid.

The push-pull output of the IC is applied to the bases of Q₄ and Q₅, which serve as two independent emitter followers. The emitters of Q₄ and Q₅ are connected through a two-conductor twisted pair to the bases of Q₁₆ and Q₁₇, on the rear circuit board. These two transistors form a differential amplifier stage having push-pull inputs and push-pull outputs. The vertical position control, R₂₉, operates by unbalancing the output stage to allow vernier positioning of the trace on the crt screen. The collectors of the vertical output transistors are directly connected to the vertical deflection plates inside the crt. L₁ and L₂ provide peaking to extend the high frequency response of the vertical amplifier system.

THE HORIZONTAL AMPLIFIER

The horizontal amplifier is similar to the vertical amplifier but is somewhat simpler because of the reduced gain and bandwidth requirements. The input circuit includes switches for selecting the various modes of operation. Normally, the Sweep Source switch, S₃, connects the input of the horizontal amplifier to the output of the sweep generator. However, this switch can also connect the horizontal amplifier input to the external horizontal-input jack on the front panel or to a small line-frequency voltage from the power supply. Note that the external horizontal input from J₃ is capacitor coupled, so its frequency response does not extend to dc. The external gain control, R₃₀, is used to control the amount of signal from the external input jack which actually reaches the horizontal amplifier input. Note that the input jack, coupling capacitor, and control are used for both external horizontal input and external triggering. However, since it makes no difference what happens to the input of the trigger circuit when external sweep is selected, no problems result from this dual configuration.

The input follower circuit in the horizontal amplifier, (Q₆, Q₇, and Q₈) is virtually identical to that used in the vertical amplifier. The only real difference is that in the horizontal amplifier one of the balance controls in the stage appears on the front panel, rather than as an internal adjustment.

The fine horizontal balance control, R₃₆, becomes the horizontal position control. This allows the horizontal position to be adjusted over a wider range than is possible in the vertical amplifier. It is possible to incorporate this feature into the input stage in the horizontal amplifier because, unlike the vertical amplifier, the gain of the horizontal amplifier is fixed so that it does not produce sudden, unwanted shifts in position.

You will note that the output of the horizontal amplifier IC₂ is coupled by a two-conductor twisted pair directly to the push-pull output stage on the rear circuit board. There are no emitter followers between the output of the IC amplifier and the bases of the horizontal output stage. Emitter followers are not needed here because the horizontal output amplifiers, Q₁₈ and Q₁₉, operate at a lower current level than those of the vertical output, and can therefore be driven directly by the IC amplifier. No peaking coils are used in the horizontal output stage since extremely high frequency response is unnecessary.

THE TRIGGER GENERATOR

The trigger, sweep, and blanking circuits are directly below the horizontal amplifier on the schematic. Since the protection circuit used in the input of the trigger generator circuit (R₅₀, C₂₅, and D₇) is similar to that used in the vertical and horizontal amplifiers, you should have no problems with overdriving. The output of the input follower, Q₉, is applied directly to one of the inputs of IC₃, which is a voltage comparator. This IC has two inputs and two outputs. The input at Pin 5 of the IC is the trigger signal and the input at Pin 4 is a dc voltage adjusted by the Trigger Level control, R₅₄, on the front panel of the scope. The outputs are digital; they have only two states—high and low, with no in-betweens possible. The two outputs are also complementary; that is, at any given time, if one output is high the other will be low and vice versa. Which output is high and which is low depends on whether the input voltage at Pin 5 is higher or lower than the reference voltage applied to Pin 4 by the Trigger Level control. Thus, if the level control is set properly, as the input voltage goes through its alternations, the voltage at Pin 5 goes from a point lower than the reference voltage to another point higher than the reference voltage. Each time the input voltage passes the point where it is equal to the reference voltage, the output terminals switch states and a trigger pulse is generated. Regardless of what the waveshape is at the input of the trigger circuit, what comes out is a rectangular waveform.

THE SWEEP GENERATOR

The sweep circuit requires a positive-going pulse at the base of Q₁₀ to initiate a sweep. The Slope Selector switch, S₅, allows the base of Q₁₀ to be fed from either output of the voltage comparator, and thereby permits the sweep to start on

either the rising (+) or falling (-) portion of the waveform. The rectangular waveform output of IC is differentiated into a narrow pulse by C₃₀ and R₅₇. Q₁₀ serves as an inverter and matches the input requirements of IC₄ to the differentiator network.

IC₄ is composed of four independent TTL (transistor-transistor logic) NAND gates.* Two of them (A and B) are cross-coupled to form a set-reset flip-flop, a third gate (C) is used as an inverter, and the fourth is unused and is not shown.

Whenever a positive pulse is applied to the base of Q₁₀, the flip-flop is set, and its output (TP₂) goes low (approximately zero volt). When the output of the flip-flop is low, transistor Q₁₁ is turned off, and there is effectively an open circuit between its emitter and collector. The selected timing capacitor (C₃₄ through C₃₈) can then charge toward +5 volts through constant current source Q₁₂. The constant charging current ensures a linear sweep waveform. The charging current is selected by the timing resistors (R₆₅, R₆₆, R₆₇, and R₆₈) in the emitter circuit of Q₁₂. These resistors are switched in and out of the circuit by the TIME/CM switch in conjunction with the various sweep timing capacitors. This is accomplished in much the same way as the attenuators and gain switching resistors are manipulated by the VOLTS/CM switch in the vertical amplifier.

The voltage across the timing capacitor is applied to the gate of source follower Q₁₃ and passed to the horizontal amplifier (terminal 12 through R₇₁ and the Sweep Source switch). The output of Q₁₃ is also applied to Pin 5 of IC₅, another voltage comparator whose function is to determine when the sweep has reached a sufficient amplitude. The comparison voltage is provided by fixed resistors R₇₂ and R₇₃. C₃₃ and R₆₉ provide positive feedback around the comparator to sharpen the switching point. The output of the comparator drives the other input (Pin 13) of the flip-flop. When the output of the comparator goes low because the sweep voltage has become high enough, the flip-flop is reset and Q₁₁ is turned on, discharging the selected sweep capacitor C₃₄-C₃₈. At this

***DIGITAL LOGIC ELEMENTS.** The four logic gates contained in IC₄ are of the NAND type. This name is an abbreviation for "not-and" and is used because each gate performs the logical AND function and because the output is inverted. Digital logic circuits operate with only two signal levels; high and low. In the case of the TTL gates used in this instrument, the "high" logic level is about +3 volts, while the "low" logic level is about +0.5 volt. No other voltages are allowed to exist at the inputs and outputs of these circuits.

An AND gate is one whose output is high only when all its inputs are high. If either one or both inputs are low, the output will be low also. If we add an inverter to the output of the AND gate, forming a NAND gate, the output will be low whenever both of the inputs are high, and high at all other times.

One of the gates has its two inputs tied together and is used as an inverter. The output of this inverter is low whenever its input is high, and vice versa. Two of the other NAND gates in IC₄ are cross-coupled and used as a flip-flop or latch circuit. The fourth gate is unused, and its inputs are connected to ground.

The two NAND gates which form the flip-flop are cross-connected so that the output of one is always high and the output of the other is always low. The flip-flop is set to one state by a pulse from the trigger generator and reset to the other state by a pulse from the sweep length comparator. In between these pulses, the flip-flop remembers the state to which it was last set and stays in that state until directed to change.

point everything halts until another trigger pulse is supplied to the base of Q₁₀. Thus we have a triggered sweep, a sweep that operates only when a trigger pulse is provided.

RETRACE BLANKING

The output of the flip-flop is buffered by inverter IC_{4C} and fed through a shielded cable to the base of the blanking amplifier transistor, Q₂₀, on the rear circuit board. This configuration applies a large negative-going pulse to the control grid of the crt during each retrace interval (the time during which the timing capacitor is being discharged). During this interval the electron beam in the crt is moving back to its starting point at the left of the screen. This retrace is blanked by cutting off the crt beam, so that it does not appear as a confusing trace on the screen.

THE POWER SUPPLY

The power supply furnishes five different output voltages to operate the crt and the various circuits in the oscilloscope, and is in the lower right-hand area of the schematic. One of these outputs is 6.3 volts ac to light the heater of the crt. A standard full wave rectifier circuit using the silicon rectifiers D₁₂ and D₁₃ provides +200 volts dc to the vertical and horizontal output stages and to the retrace blanking amplifier on the rear circuit board. An 800-volt winding on the power transformer, together with a voltage doubler circuit using diodes D₁₄ and D₁₅, provides about -2000 volts to operate the crt. This negative voltage is applied to the cathode and grids of the crt.

The intensity control, R₈₂, varies the strength of the electron beam in the crt by changing the effective grid-to-cathode voltage in the electron gun. Note that the high voltage is not regulated; changes in ac line voltage will produce corresponding changes in the amount of high voltage applied to the crt. Since changes in high voltage will change the deflection sensitivity of the crt, the calibration of the scope is valid only as long as the ac line voltage remains unchanged. Fortunately, however, normal variations in ac line voltage will not produce any noticeable effect on the calibration of the scope.

Most of the circuits in the oscilloscope operate from the plus and minus 5 volt supplies which are on the front circuit board. These power supplies are tightly regulated for changes in load current and power line voltage. Rectifiers D₈ and D₉ supply a positive input voltage for IC₆, a 3-terminal voltage regulator that furnishes a stable +5 volt output. Rectifiers D₁₀ and D₁₁ furnish a corresponding negative voltage to the collector of Q₁₅. IC₇ is an operational amplifier that is connected to provide tracking between the +5 and -5 volt outputs. Since the output of the +5 volt regulator should never change for any reason, it is used as a reference in establishing the output level of the negative regulator. Q₁₅ is a series pass transistor. Q₁₄ is used for short-circuit current limiting to protect Q₁₅ and IC₇ against possible short circuits from the -5 volt line to ground. A similar circuit is built into IC₆ to provide the same kind of protection for the +5 volt regulator.

TEST PROBES

In some test applications you will be able to use the test leads supplied with this kit for connecting the oscilloscope to the equipment you are testing. If you want an extra set of test leads, you can purchase complete sets or individual parts at any wholesale supply house. Two sets, one with clips and one with plugs, give maximum convenience. The plugs can be used in preliminary analysis and the clips for more involved tests. The alligator clip lead is more useful for ground connections.

As indicated in the last section, you will have occasion to use special probes of various types with your oscilloscope. For example, you will frequently need a shielded cable input to avoid hum pickup. Unfortunately, the shielded cable itself acts as a capacitor in parallel with the vertical amplifier input, and this may cause excessive capacitive loading in some circuits. To avoid this situation, a low-capacity probe can be used.

The low-capacity probe represents the simplest method of overcoming the ill effects of the added capacitance of the shielded cable. Figure 57 is a schematic of the basic low-capacity probe. Note that there is a resistive voltage divider consisting of the 1 megohm input impedance of the scope and the 9 megohm resistor in the probe. This 9:1 ratio of resistance produces a 10:1 voltage division at the scope input as compared to the voltage at the tip of the probe. This is because nine-tenths of the voltage is dropped across the 9

megohm resistor, leaving only one-tenth across the 1 megohm resistance of the oscilloscope. This resistive divider in itself would be enough to isolate the probe tip from the capacitive loading effect of the oscilloscope and cable. However, the high-frequency response of the oscilloscope would be rolled off severely, since the 9 megohm resistor would form a low-pass network with the shunt capacitance. This undesirable effect is prevented by shunting the 9 megohm resistor with a capacitor whose value is selected to be one-ninth that of the total of the scope input and cable capacitances. In the example shown, the scope input capacitance is 30 pf and the cable capacitance is 90 pf, for a total of 120 pf. This means that the probe compensating capacitor must be $120/9$ pf, or about 13.3 pf. In practice, this small capacitor is a variable one so that the response of the probe can be optimized. When the capacitance of the compensating capacitor is one-ninth that of the shunt capacitance, its reactance is nine times as high as that of the shunt capacitance at any given frequency. A 10:1 voltage division will therefore result at high frequencies, just as the resistors produce at low frequencies and dc. The net effect is that the probe/scope combination has a constant voltage division ratio at all frequencies, and so the probe will pass the signal to be observed without distortion.

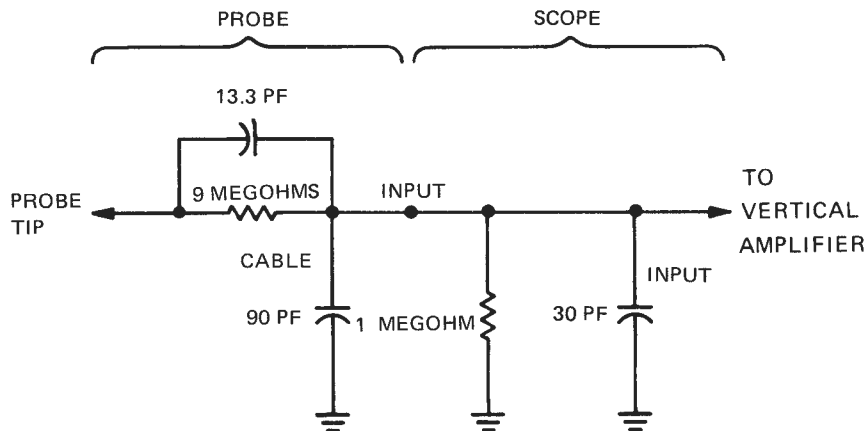

Fig. 57. Basic LC probe.

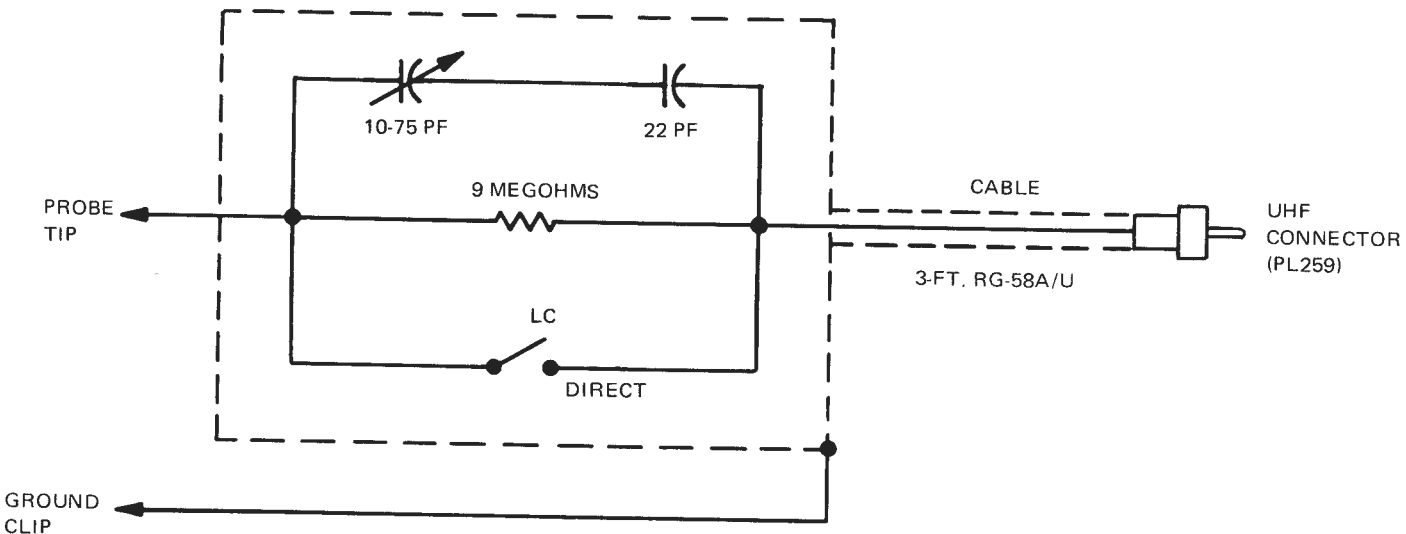

Fig. 58. Combination LC/direct probe.

Figure 58 shows a combination low-capacity/direct probe. This probe is the same as the one shown in the previous figures, but a switch has been added to short out the RC network, thus permitting a direct connection to the circuit under test. The direct position should be used *only* when the capacitive loading of the cable and scope input will not affect the circuit under test. Normally, the direct position is needed only for measuring very small signals, such as power supply ripple, when the maximum sensitivity of the scope is needed. Remember, whenever the switch is in the LC position, the probe attenuates the signal by a factor of 10.

THE DETECTOR PROBE

The detector probe demodulates an rf or i-f signal, and applies only the modulation to the scope input. With this type of probe, you can readily trace the signal through the video i-f stages of a TV receiver. This type of probe is also useful in stage-by-stage alignment of a TV video i-f amplifier (some manufacturers give stage-by-stage response curves).

A typical detector probe is shown in Fig. 59. To use this probe, simply clip the ground lead to the receiver B-connection, and touch the probe tip to the point where you wish to observe the signal.

It is impossible to say in which stage of the video i-f amplifier you will be able to pick up the signal, because that depends upon the signal strength in your area and upon the receiver gain. In high-signal areas, you may be able to pick up a signal at the output of the first video i-f stage; in low-signal areas, you may not be able to pick up a signal until it has been amplified by the first two video i-f stages. If you can pick up a signal at the output of the first stage, you can trace the signal by moving the probe to the input of the second stage, and so on, until you reach the video detector. Beyond the video detector you can use the low-capacity probe to trace the signal to the picture tube. In some areas, the signal may be so strong that with the high gain of your scope vertical amplifier you can pick up TV signals right from the antenna leads with a detector probe. This, however, is very unusual.

RESISTOR-ISOLATED PROBE

This probe, shown in Fig. 60, is very useful in sweep alignment work. The series resistor isolates the circuit under test from the oscilloscope input and cable capacitances. Since the resistor is not shunted by a compensating capacitor, the network also serves as a low-pass filter, sharpening broad marker pips which would otherwise mask portions of the trace.

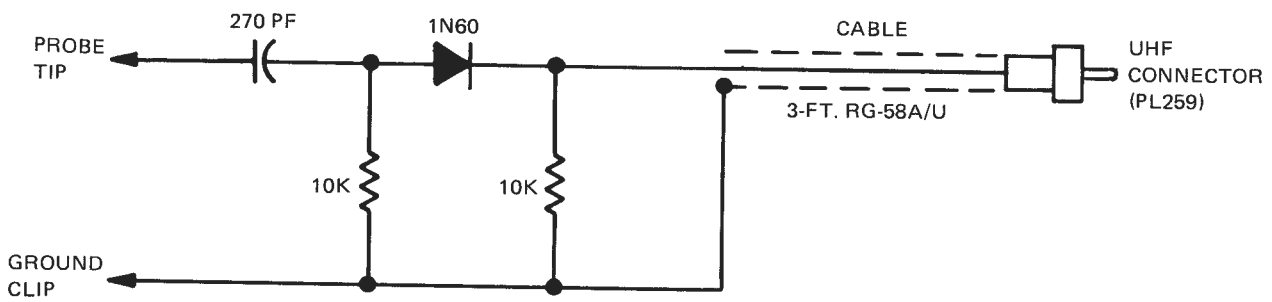

Fig. 59. Detector probe is easily assembled from readily available parts.

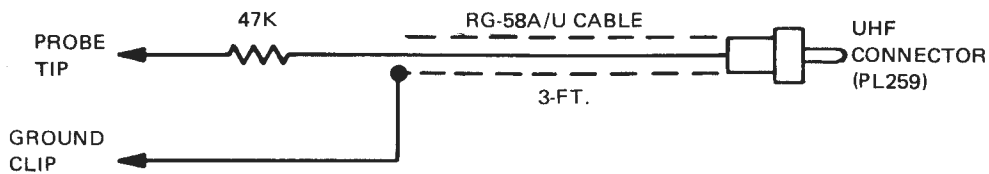

Fig. 60. Resistor-isolated probe.

HIGH-VOLTAGE CAPACITANCE-DIVIDER PROBE

Most TV manufacturers show what waveforms to expect at various high-potential points in the horizontal output stage. To view these waveforms, you must use a probe such as the one shown in Fig. 61. This probe reduces the input signal amplitude by a factor of 100 to 1 without noticeably changing the waveform. (The tube in this probe is not used as a rectifier, but merely as a high-voltage low-capacitance capacitor.) This type of probe is required only in testing the horizontal sweep voltage. You cannot buy it from your dealer—if you want one you must buy the parts and build it. It is very important that you provide an insulating cover for the probe. The top cap of the tube should extend beyond the end of the insulating cover, and it serves as the probe tip. When using the probe, keep your hand as far as possible from the probe tip. **USE EXTREME CAUTION WHEN MAKING HIGH-VOLTAGE MEASUREMENTS.**

Precise 100 to 1 attenuation is obtained by adjusting the trimmer in the probe. To make this adjustment, first measure precisely the amplitude of a horizontal-frequency signal of roughly 100 volts peak-to-peak, using the combination probe

set to its direct position. You will have to set the VOLTS/CM switch to the "20" position to make this measurement. You will be able to find such a signal at the grid of the horizontal output tube in a typical tube-type TV receiver. Now, after you know the exact amplitude of the signal, connect the high voltage probe in place of the combination probe, move the VOLTS/CM switch to its "0.2" position, then set the trimmer on the high voltage probe to give exactly the same amplitude on the scope as you noted with the direct connection. The probe is then calibrated to give exactly a 100 to 1 attenuation factor. Note that since there is no resistor in parallel with the high voltage capacitor, the response of this probe is limited to relatively high frequencies, and cannot be used to measure dc voltages.

Before attempting to view extremely high-voltage waveforms with the scope, check the probe by connecting a 1 megohm resistor across the output of the cable (without connecting the probe to the scope) and connecting the probe input to the plate of the horizontal output tube in an operating tube-type TV receiver. If the 1X2 tube in the probe turns blue or arcs internally, you must select another tube to use. The scope input would be damaged if that tube were used. Be sure to calibrate the probe with a non-arcing tube.

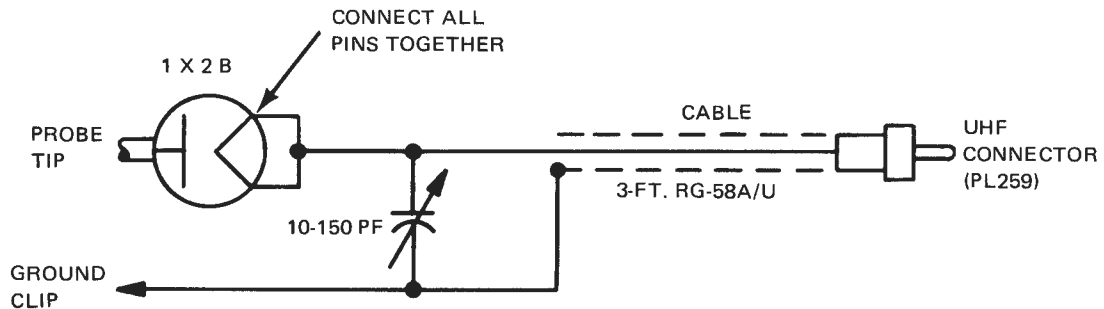

Fig. 61. High-voltage 100 to 1 probe.

MAINTENANCE

TROUBLESHOOTING THE SCOPE

If you had trouble making any of the calibration adjustments, there may be an electrical defect in your scope. Our experience has shown that by far the most frequent cause of such trouble is faulty solder connections. Check your solder job very carefully once again, especially on the two printed circuit boards. Make sure that no adjacent IC pins are accidentally shorted together by a blob of solder.

Check to make sure that all components are installed, and that the six plug-in integrated circuits are fully seated in their sockets. Be doubly sure that each of the IC's is oriented correctly, and that all of its pins are engaged in its socket.

One effective way of troubleshooting the scope is to check the dc voltages and compare them with those in Table 3. Set all the front panel controls, except Trigger Source, as shown in Table 1 before you take these measurements. Set the Trigger Source to INT. All voltage measurements shown in

TABLE 3

MODEL 255 VOLTAGE CHART
FOR ALL TRANSISTORS AND INTEGRATED CIRCUITS

TRANSISTORS							
	E/S	B/G	C/D		E/S	B/G	C/D
Q ₁	+1	0	+4.8	Q ₁₁	0	+0.7	+0.1
Q ₂	-2.8*	-2.2*	+0.7	Q ₁₂	+3.7	+3	+0.1
Q ₃	0	+0.7	+4.8	Q ₁₃	-0.1	+0.1	+5
Q ₄	+1.8	+2.5	+5	Q ₁₄	-5	-5.5	-6.2
Q ₅	+1.8	+2.5	+5	Q ₁₅	-5.5	-6.2	-12
Q ₆	+1	0	+5	Q ₁₆	+1.1	+1.8	+120
Q ₇	-2.7*	-2.3*	+0.7	Q ₁₇	+1.1	+1.8	+120
Q ₈	0	+0.7	+5	Q ₁₈	+1.8	+2.5	+120
Q ₉	+0.5	0	+5	Q ₁₉	+1.8	+2.5	+120
Q ₁₀	0	0	+5	Q ₂₀	+2.9	+3.6	+190

bipolar
E – emitter
B – base
C – collector

FET
S – source
G – gate
D – drain

INTEGRATED CIRCUITS														
PIN	1	2	3	4	5	6	7	8	9	10	11	12	13	14
IC ₁	0	+4.8	-0.8	-0.7	-5	-5	+2.5	+2.5	-5	+4.8	-0.7	-0.8	0	0
IC ₂	0	+5	-0.8	-0.7	-5	-5	+2.5	+2.5	-5	+5	-0.7	-0.8	0	0
IC ₃	+0.5	+0.5	+0.5	+0.5	+0.5	-5	-5	0	0	†	†	+5	+5	+5
IC ₄	0	0	+4.8	+0.1	+0.1	+3.6	0	+0.1	+5	+3.2	+3.2	+0.1	+3.5	+5
IC ₅	+0.45	+0.45	+0.45	+0.45	-0.1	-5	-5	0	0	+3.5	+0.1	+5	+3.5	+3.5
IC ₆	+12	+5	0											
IC ₇	-12	0	0	-12	-12	-6.2	+12	+12						

* Depending on FET Parameters.

† Depends on rest position of input—one pin will be +0.1, the other +3.6.

the Table are dc, unless otherwise specified. Remember to allow at least $\pm 10\%$ tolerance in your voltage measurements, because of component tolerance and meter accuracy.

CAUTION

In taking voltage measurements, keep your hands off the chassis and wiring, and be careful where you put your meter probe. There are dangerous voltages on the chassis and on the intensity and focus controls.

Do not attempt to measure the high dc voltage applied to the cathode, heater, grid or first anode of the crt unless it is absolutely necessary to do so. If you are going to measure the high dc voltages, you *must* use a high-voltage probe with your tvom. Instead of measuring these voltages, we suggest that you measure the voltage at the low end of the focus control (terminal 3); this voltage should be about -700 volts. If it is correct, you know that the high ac and dc voltages are correct and there is little need therefore to try to measure the output from the high-voltage supply.

If the voltage at terminal 3 of the focus control is incorrect, you can probably find the trouble by making a few ohmmeter checks. Compare the resistance measurements you obtained with the schematic diagram. Be sure the scope is disconnected from the power line and you have allowed time for all filter capacitors to discharge before you attempt any resistance measurements.

The 220-volt power supply furnishes operating power for the vertical and horizontal output stages as well as for the retrace blanking amplifier, and also for the crt accelerating anode. If this voltage is low, maximum deflection will be limited. In the worst case, where the output of this power supply is 0 volt, there will be no deflection at all and the astigmatism control will have no effect, although it should be possible to focus the dot which remains on the crt screen.

When you turn on the power switch, the pilot lamp on the front panel should light immediately, and the crt heater should begin to glow. After 15 seconds or so, you should see a trace on the screen. If nothing at all happens when you turn on the power switch, the fuse could be open, the scope could be connected to a dead ac outlet, or there could be a miswiring in the power transformer primary circuit. If the pilot lamp glows, but the crt heater does not, the power transformer may be miswired, or the crt heater may be open.

If both the pilot lamp and crt heater operate normally but there is no trace, the trouble could be in one of the dc power supplies or in the deflection amplifiers. Remember, the lack of a trace on the screen is *not* proof that the high voltage is missing; it could be that the trace is there, but is being deflected off-screen by an unbalanced amplifier. Since all the deflection amplifiers are direct-coupled, the trouble could be anywhere from the output stages back to the vertical and horizontal input jacks. A thorough check of the dc voltages of the amplifiers will isolate this type of trouble.

The +5 volt regulator incorporates internal current limiting to protect the regulator in case of excessive current demand. For example, if the +5 volt line is shorted to the chassis, the voltage on the +5 volt line will be zero, although the regulator would be unharmed by this condition. If the +5 volt supply is missing, it could be because of a fault in the rectifier or regulator circuits, or because of a shorted load. To tell which is the case, turn off the oscilloscope and measure the resistance from the +5 volt line (TP1) to ground. If you find a short circuit here, the regulator and rectifiers are probably working normally. As soon as you locate and remove the short circuit from the +5 volt line, you should then find that the output voltage is normal. If, on the other hand, the resistance is normal (about 200 ohms, depending upon ohmmeter polarity), check to see if there is any dc voltage at the input to the regulator (Pin 1—about +12 volts). If this voltage is present, if there is no voltage at Pin 2, and no short is present, IC₆ must be faulty. If there is no voltage at Pin 1 of IC₆, D₈ or D₉ may be defective or C₄₄ could be shorted.

If there is no output from the +5 volt regulator for any reason, there will also be no output from the -5 volt regulator, since the negative regulator is designed to “track” the output of the positive regulator so that the two output voltages remain equal. Therefore, if you note that there is no output from the negative regulator, before you check to see if there is anything wrong in this part of the oscilloscope, check to see if the +5 volt regulator is working. If there is a normal +5 volts, the reason for the low or missing -5 volts could be excessive current drain or a fault in the negative regulator. If the problem is being caused by excessive current drain, you will find a fairly large voltage drop (on the order of 1 volt) across R₈₁, the current limiter sense resistor. If the voltage across R₈₁ is much less than this, the trouble is probably in the negative regulator itself. Or, the rectifiers could be faulty, or the input filter capacitor (C₄₅) could be open or of insufficient capacitance. Note that ripple in the output of either 5 volt supply can be caused by an open or low-capacitance input filter capacitor, or by an open rectifier (D₈-D₁₁).

If all power supply voltages are normal, yet there is no trace on the screen, the trouble is probably in one of the deflection amplifiers. Try performing the balancing adjustments in the calibration procedure to see if they will correct the problem. If not, compare the dc voltages in the amplifiers with those listed in Table 3. Or, you may wish to use another oscilloscope to signal-trace the amplifiers. Inject a sine wave signal at the horizontal or vertical amplifier input and follow it through the various stages to see where it is lost or distorted.

You may also find another oscilloscope very helpful in troubleshooting the trigger generator. Inject a sine wave signal into the vertical amplifier input, select internal triggering, then trace the sine wave through Q₉ and IC₃. The signal should pass undistorted through Q₉, and should appear as a square wave at the outputs (Pins 10 and 11) of IC₃. You should be able to vary the duty cycle of the square wave with the trigger level control, provided that the trigger balance control (R₅₂) is properly set.

The selected output of IC₃ is applied to a differentiator circuit, and is then inverted by Q₁₀, so the signal at Pin 9 of IC₄ should be a very narrow negative-going pulse.

The sweep generator, consisting of IC₄, IC₅, Q₁₁, Q₁₂, and Q₁₃, is a closed loop. If the circuit is not generating sawtooth waveforms, you won't find any signals at any point in this circuit. Therefore, an oscilloscope is not very useful for troubleshooting in this case. Make sure that the front panel controls are set as shown, then compare your dc voltage measurements in the sweep circuit with those listed in Table 3.

If the sweep generator is running, yet there is no sweep on the screen, check the signal path through R₇₁ and S₃ to the input of the horizontal amplifier. Do not overlook the possibility that the lack of sweep is being caused by severe imbalance of the horizontal amplifier. Possibly adjusting R₄₁ will correct the problem. For a complete troubleshooting check list, see Table 4.

TABLE 4
TROUBLESHOOTING CHECK LIST

PROBLEM	PROBABLE CAUSE
(a) Pilot lamp not lit, no trace.	<ol style="list-style-type: none"> 1. Blown fuse—must be slow-blow type. 2. Dead ac outlet. 3. T₁ miswired. 4. S₇ miswired.
(b) Pilot lamp not lit, trace normal.	<ol style="list-style-type: none"> 1. I₁ leads shorted. 2. S₇ miswired.
(c) Pilot lamp lit, no trace.	<ol style="list-style-type: none"> 1. -2000 volt supply. 2. Intensity and focus controls. 3. Vertical amplifier unbalanced. 4. Horizontal amplifier unbalanced.
(d) Trace cannot be moved or centered vertically.	<ol style="list-style-type: none"> 1. Vertical amplifier. 2. CRT wiring (Pins 6 and 7). 3. L₁ or L₂ open.
(e) No vertical deflection.	<ol style="list-style-type: none"> 1. Vertical amplifier. 2. S₂ miswired or in wrong position. 3. S₁ miswired or in "GND" position.
(f) Trace cannot be moved horizontally.	<ol style="list-style-type: none"> 1. Horizontal amplifier. 2. CRT socket wiring (Pins 9 and 10).
(g) No horizontal deflection.	<ol style="list-style-type: none"> 1. Horizontal amplifier. 2. S₃ miswired or in "EXT" position.
(h) No internal sweep, line sweep okay.	<ol style="list-style-type: none"> 1. Sweep generator. 2. Trigger generator. 3. S₄ miswired or in "EXT" position. 4. Trigger balance (R₅₂) misadjusted. 5. Trigger signal of insufficient amplitude.
(i) Trace cannot be moved either vertically or horizontally.	<ol style="list-style-type: none"> 1. +220 volt supply. 2. ±5 volt supply.
(j) Poor focus at edges of trace, center focus okay.	<ol style="list-style-type: none"> 1. Astigmatism control misadjusted. 2. Horizontal bias (R₄₈), misadjusted.
(k) Trace jumps vertically when VOLTS/CM switch is moved.	<ol style="list-style-type: none"> 1. Vertical amplifier unbalanced—adjust R₁₂ and R₁₅. 2. Q₁ or D₁ leaky—replace.
(l) Signal at low voltage ac test point not a good sine wave.	<ol style="list-style-type: none"> 1. Normal condition caused by uneven loading of power transformer windings by low voltage rectifiers.

TABLE 4 (continued)

PROBLEM	PROBABLE CAUSE
(m) All power supply output voltages low.	<ol style="list-style-type: none"> 1. T₁ primary wired for 230 volts. 2. T₁ faulty.
(n) Hum in trace.	<ol style="list-style-type: none"> 1. C₄₄ or C₄₅ open or too low in capacitance. 2. IC₆ shorted. 3. IC₇ or Q₁₅ faulty. 4. C₄₃ defective. 5. Vertical or horizontal input connecting cables not shielded. 6. Low voltage rectifier (D₈-D₁₁) open.
(o) No retrace blanking.	<ol style="list-style-type: none"> 1. Q₂₀ defective. 2. IC₄ defective. 3. CRT socket miswired (Pins 2, 3, 4, and 5). 4. Shielded cable from hole F shorted.

IN CASE YOU HAVE TROUBLE WITH YOUR OSCILLOSCOPE

If you are unable to get your scope going, write to us and thoroughly describe the symptoms you have observed. Be sure to enclose a copy of your voltage measurements. We will then give you suggestions on servicing the oscilloscope.

If you are still unable to repair your oscilloscope, write to us again and we will either make further recommendations or authorize you to return the instrument to us for repair.

NOTICE

Do not send in your oscilloscope for repair without authorization. Oscilloscopes received without prior authorization will be returned unrepared, shipping charges collect.

At the time you ship the scope to us for repair, enclose your remittance of \$15.00 for the service charge. In the event that

parts must be replaced because of damage from wiring or assembly errors or poor soldering, we will bill you for the cost of the necessary parts. If we find that improper operation was due to defective parts, these will be replaced without charge, and your \$15.00 will be refunded. If you return your scope for repair, proceed as follows:

1. Ship the scope in its cabinet with the side panels in place. Do *not* include the crt, bezel, and graticule.
2. Use a carton large enough to pack two or more inches of crumpled newspaper or other suitable packing material tightly around the oscilloscope *on all sides* to avoid shifting.
3. Mark "This side up — Electronic Instrument — Do not drop" on top of the shipping carton.
4. Ship only by prepaid Railway Express or prepaid United Parcel Service, not Parcel Post. Damages are certain if the instrument is shipped by Parcel Post, and we will not be responsible.
5. Be sure to insure your oscilloscope for the full amount of a wired instrument.
6. Enclose all correspondence, questions, or other information to guarantee prompt and efficient service.

Quan.	Part No.	Description	Price Each
RESISTORS (1/2-watt unless otherwise noted)			
1	RE188	3.3 ohm, 5%	.24
1	RE1	10 ohm, 5%	.25
1	RE3	100 ohm, 5%	.25
1	RS6	100 ohm, 10%, 1-watt	.20
3	RE186	120 ohm, 5%	.24
2	RE159	180 ohm, 5%	.25
1	RE187	270 ohm, 5%	.24
2	RE126	330 ohm, 5%	.25
3	RE161	470 ohm, 5%	.25
1	RE175	680 ohm, 5%	.24
11	RE164	1k-ohm, 5%	.25
1	RE102	3k-ohm, 5%	.25
2	RS37	3k-ohm, 10%, 10-watt	.50
2	RE202	4.7k-ohm, 5%	.24
1	RE50	6.8k-ohm, 10%	.15
7	RE74	10k-ohm, 5%	.25
1	RS5	10k-ohm, 10%, 1-watt	.20
1	RE6	16k-ohm, 5%	.25
2	RS42	18k-ohm, 10%, 2-watt	.30

Quan.	Part No.	Description	Price Each
2	RE10	100k-ohm, 5%	.25
1	RE184	110k-ohm, 5%	.24
1	RS92	150k-ohm, 10%, 1-watt	.20
1	RE37	220k-ohm, 10%	.15
1	RE16	390k-ohm, 5%	.25
5	RE158	470k-ohm, 5%	.25
1	RE185	910k-ohm, 5%	.24
10	RE73	1 megohm, 5%	.25
2	RE75	1.5 megohm, 10%	.15
1	RE23	3.3 megohm, 5%	.25

CAPACITORS

3	CN317	4-40 pf trimmer	.40
1	CN180	6.8 pf disc	.15
1	CN282	12 pf, 5%, silver mica	.25
2	CN151	56 pf disc	.08
1	CN113	75 pf disc	.10
1	CN220	82 pf disc	.15

Quan.	Part No.	Description	Price Each
1	CN290	270 pf, 5%, silver mica	.35
1	CN43	0.001 μ f, 3 kV disc	.30
2	CN218	0.001 μ f, 10% disc	.15
1	CN315	0.003 μ f, 5%, 600 V poly	.30
3	CN245	0.005 μ f, 10% disc	.22
13	CN86	0.01 μ f, 1 kV disc	.18
1	CN82	0.01 μ f, 2 kV disc	.22
1	CN85	0.01 μ f, 10% disc	.16
1	CN244	0.01 μ f, 150 VAC disc	.25
1	CN316	0.03 μ f, 5%, 200 V mylar	.25
3	CN146	0.05 μ f, 3 kV	.95
1	CN104	0.1 μ f, 50 V disc	.36
1	CN309	0.1 μ f, 10%, 200 V mylar	.30
2	CN135	0.1 μ f, 600 V mylar	.30
1	CN313	0.47 μ f, 200 V mylar	.50
5	CN261	1 μ f, 10% tantalum	.74
1	CN256	10 μ f, 10 V electrolytic	.35
1	CN300	10 μ f, 10% tantalum	.50
1	CN116	30-30 μ f, 350 V can	1.25
1	CN149	50 μ f, 250 V tubular electrolytic	.82
1	CN257	100 μ f, 10 V electrolytic	.45
2	CN279	330 μ f, 16 V or 400 μ f, 15 V electrolytic	.40

Quan.	Part No.	Description
TRANSISTORS AND DIODES		
5	CR23	1N914 diode
2	SR15	High voltage rectifier
4	SR17	E1 or 1N4001 diode
2	SR24	E10 or 1N4007 diode
4	TS20	2N5457 transistor
3	TS21	2N5134 transistor
2	TS22	2N5138 transistor
5	TS28	2N3692 transistor
5	TS34	MPS-U10, D40N1, or 40887 transistor
1	TS35	2N6124, 2N6111, or TIP32 transistor
2	TS42	2N5458 transistor
INTEGRATED CIRCUITS		
1	IG5	7400
1	IG34	741
2	IG36	733
2	IG37	760
1	IG38	7805

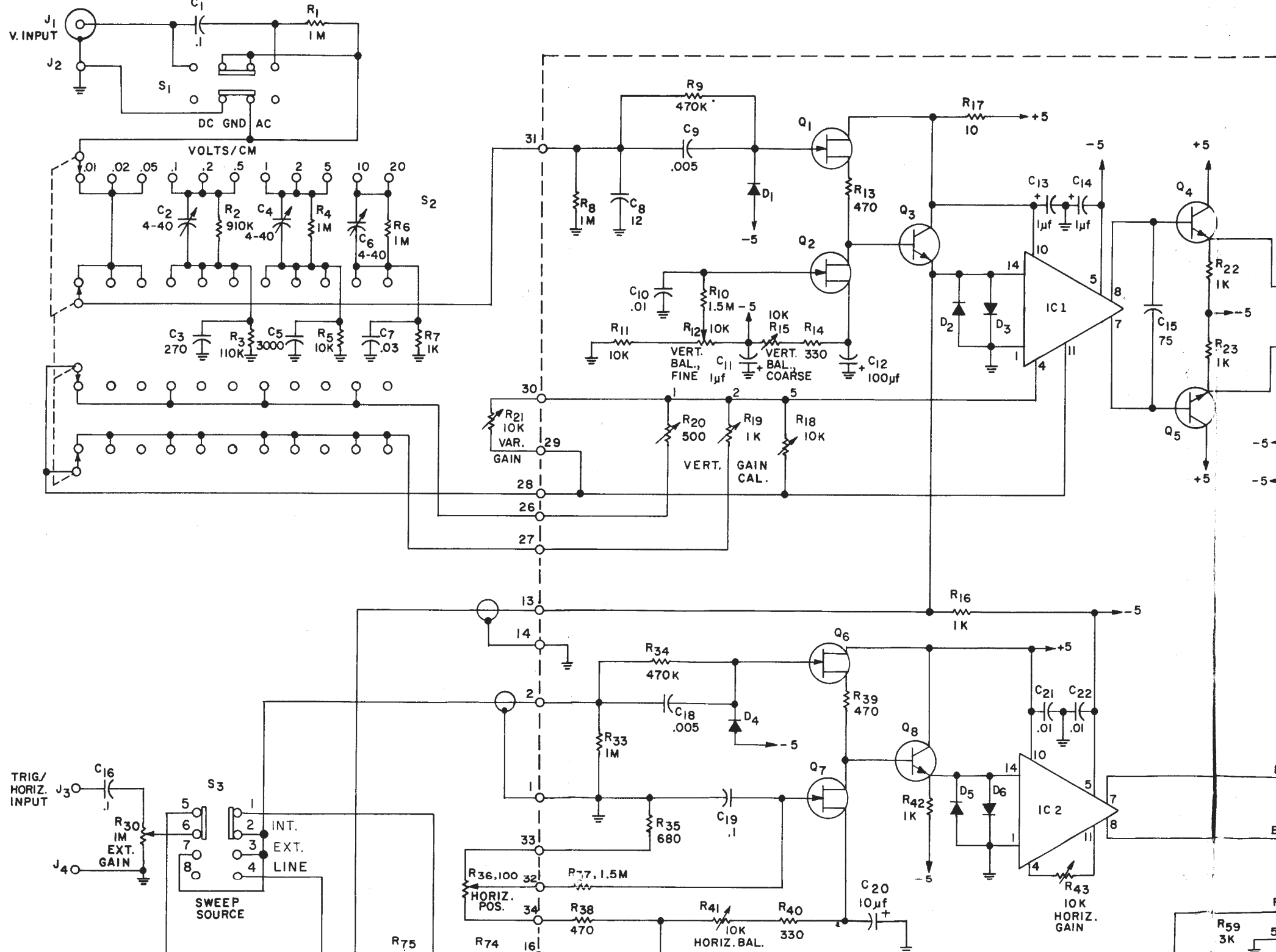

NOTES:

1. ALL RESISTOR VALUES IN OHMS, K=1000, M=1000000
2. ALL CAPACITOR VALUES UNDER 1 IN μf , OVER 1 IN PF UNLESS OTHERWISE SPECIFIED
3. INDUCTANCE IN μH

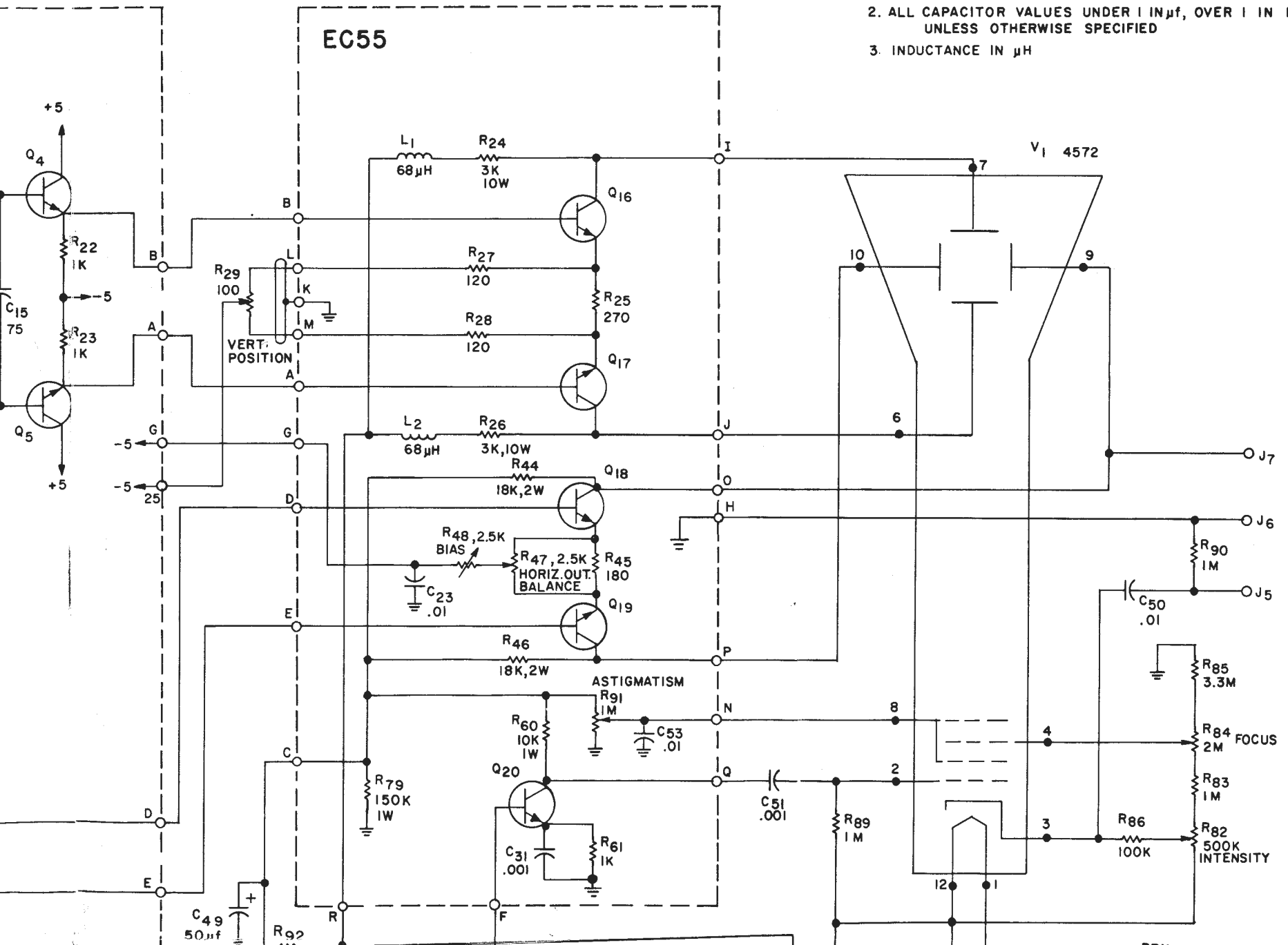

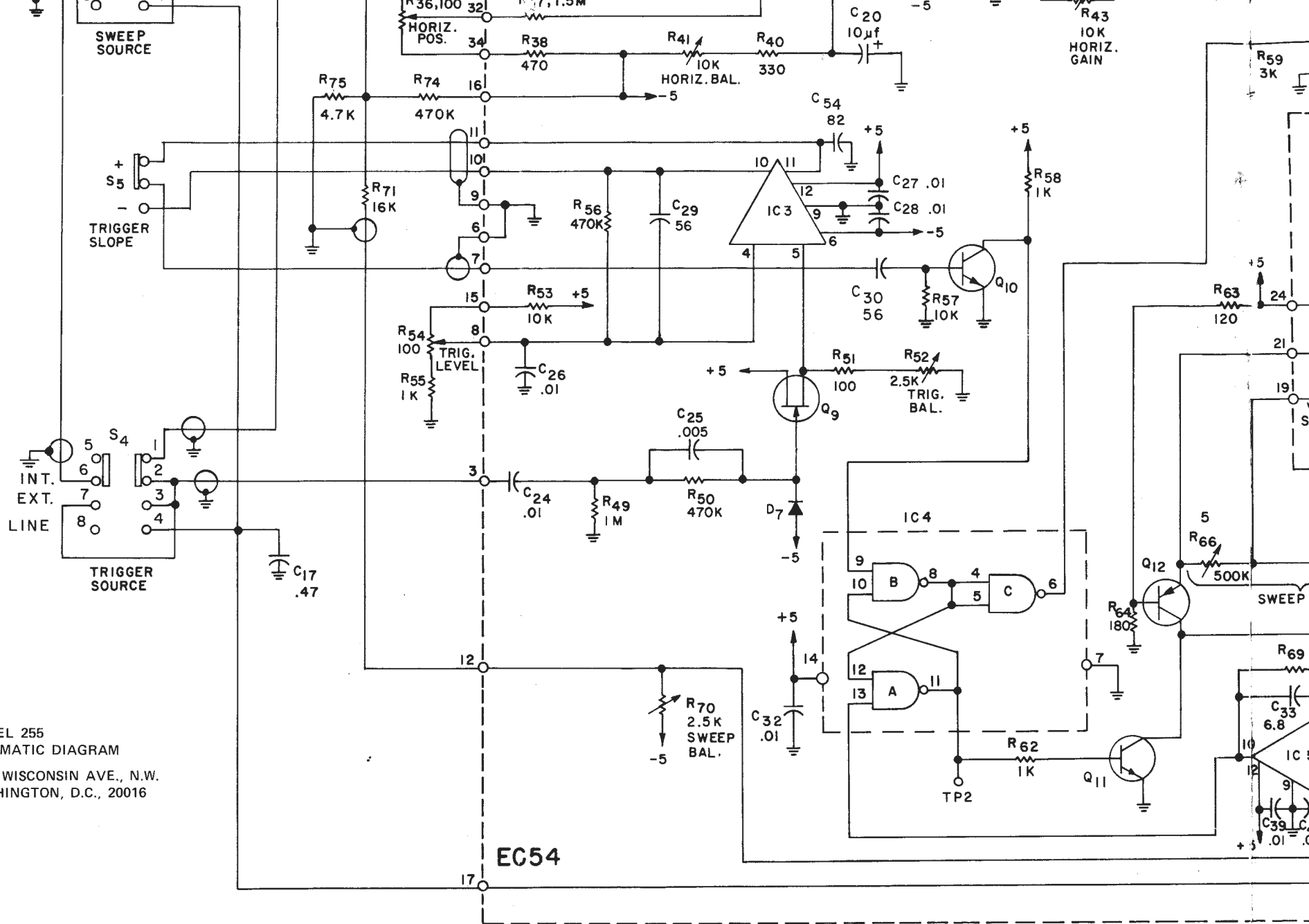

MODEL 255
 SCHEMATIC DIAGRAM
 3939 WISCONSIN AVE., N.W.
 WASHINGTON, D.C., 20016

EC54

